

ST series

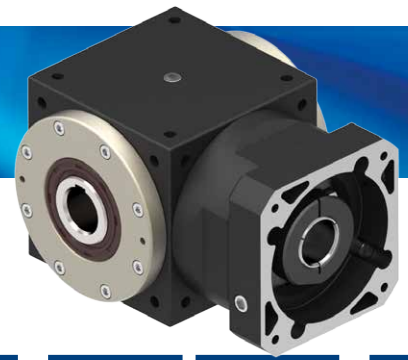

Indication of Model Numbers

機種型號表示

ST	90	F	N	B	5	L	P0
減速機機型 Type	型號 Model	入力表示 Input	出力表示 Output	軸承形式 Bearing	速比 Ratio	軸向 Shaft Direction	背隙等級 Backlash Class
ST	65 75 90 110 140 170 210 240 280	F: 入力法蘭 Input Flange R44: 減速機 Reducer 1-Stage: R44、R62... 2-Stage: R62S... 2-Stage (A-Type): R44A、R62A... D: 單入力軸心 (有鍵槽) Single Input Shaft (Keyway) D1: 單入力軸心 (無鍵槽) Single Input Shaft (No Keyway) Y: 雙入力軸心 (有鍵槽) Double Input Shaft (Keyway) Y1: 雙入力軸心 (無鍵槽) Double Input Shaft (No Keyway)	O: 出力中空軸 Hollow Output Shaft N: 單邊免鍵軸套 (有鍵槽) Single Clamping (Keyway) N1: 單邊免鍵軸套 (無鍵槽) Single Clamping (No Keyway) M: 雙邊免鍵軸套 Double Clamping S: 單出力軸心 (有鍵槽) Single Output Shaft (Keyway) S1: 單出力軸心 (無鍵槽) Single Output Shaft (No Keyway) V: 雙出力軸心 (有鍵槽) Double Output Shaft (Keyway) V1: 雙出力軸心 (無鍵槽) Double Output Shaft (No Keyway) P: 螺桿式 Ball Screw (75#~210#) 限用滾錐軸承 Taper Bearing Only	B: 滾珠軸承 Ball Bearing (65#~280#) (Ratio: 1~5) T: 滾錐軸承 Taper Bearing (75#~280#) (Ratio: 2~5)	單段 1-Stage 1, 2, 3, 4, 5 ----- 搭配單段 行星減速機 With 1-Stage Planetary Reducer 10 ~ 50 ----- 搭配雙段 行星減速機 With 2-Stage Planetary Reducer 75 ~ 500	L: 左軸 Left Shaft R: 右軸 Right Shaft ----- 1. 出力形式 N、S 可以選 擇軸向 Shaft direction is optional for output type N, S. ----- 2. 出力形式 P 為 R 軸向 Output type P only for R shaft.	P0 P1 P2

The Model & Ratio Table of Bevel Gear Reducer Assembly Planetary Reducer

傘齒輪減速機搭配行星減速機型號及速比一覽表

Model	Ratio	法蘭盤框號 Flange Model	行星減速機框號 Planetary Reducer Model	單段行星減速機減速比 Ratio of 1-Stage Planetary Reducer 5、10	雙段行星減速機減速比 Ratio of 2-Stage Planetary Reducer 25、50、100
65	1 2 3 4 5	62	44	搭配單段行星減速機減速比 Ratio of Bevel Gear Reducer Fitted with 1-Stage Planetary Reducer 10、15、20、25、30、40、50	搭配單段行星減速機減速比 Ratio of Bevel Gear Reducer Fitted with 1-Stage Planetary Reducer 75、100、125、150、200、 250、300、400、500
75		62	44、62		
90		90	62		
110		90	80		
140		120	90		
170		142	120		
210		180	142		
240		220	180		
280		220	220		

Selection of Type

產品樣式選擇

入力形式 Input Type

F 入力法蘭
Input Flange

R 減速機
Reducer

D 單入力軸心
Single Input Shaft

Y 雙入力軸心
Double Input Shaft

O
出力中空軸
Hollow
Output
Shaft

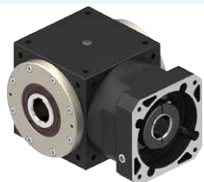

FO



RO

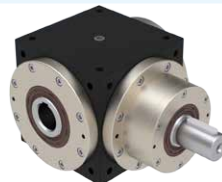

DO

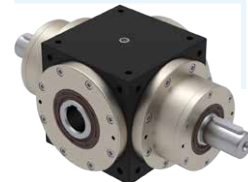

YO

N
單邊
免鍵軸套
Single
Clamping



FN



RN



DN

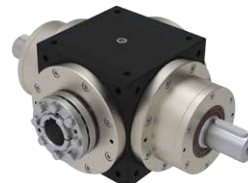

YN

M
雙邊
免鍵軸套
Double
Clamping



FM



RM



DM



YM

S
單出力軸心
Single
Output Shaft



FS



RS



DS



YS

V
雙出力軸心
Double
Output Shaft



FV



RV



DV



YV

P
螺桿式
Ball Screw



FP



RP



DP

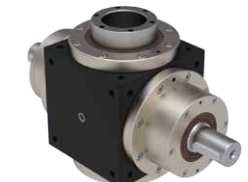

YP

出力形式 Output Type

- 出力形式 N、S 可以選擇軸向。 Shaft direction is optional for output type N, S.
- 出力形式 P 為 R 軸向。 Output type P only for R shaft.

Rotating Direction

旋轉方向說明

ST

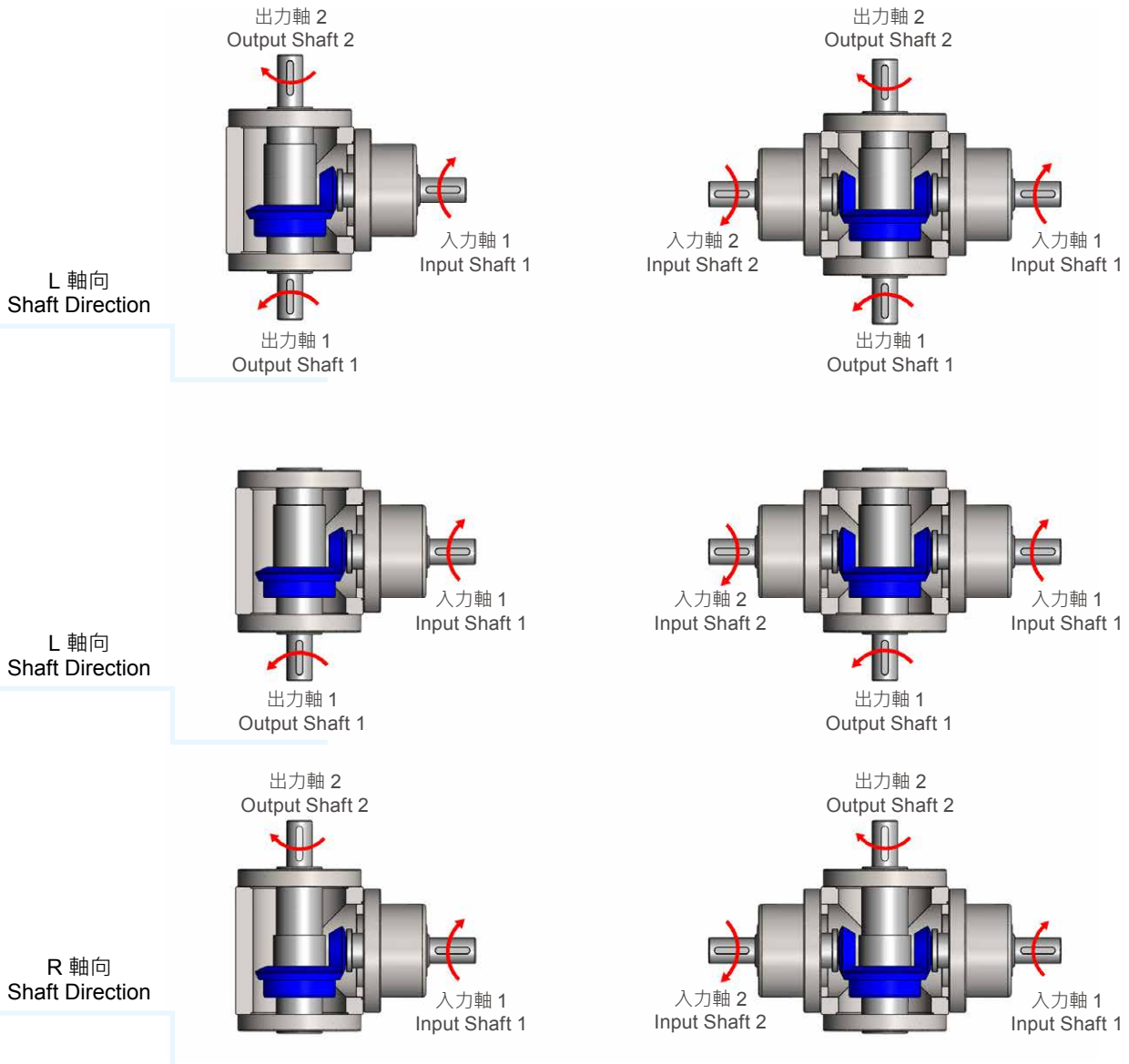
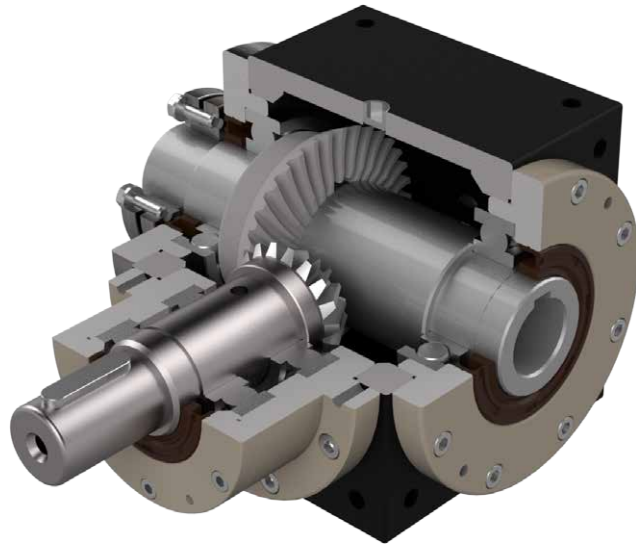

Note:
 本公司出廠標準品使用「標準軸向」，R 軸向請於訂單上註明。
 Standard product is L shaft direction, R shaft direction is optional.

Selection Direction of Installation

安裝方向選擇

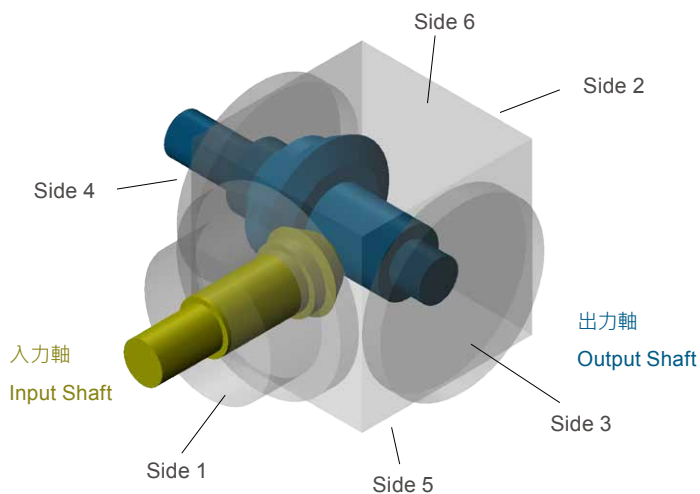

Side 1	Side 2
Side 3	Side 4 [Note 1]
Side 5	Side 6

[Note 1] 出力軸端面基準線朝上時，需特別告知其使用方式。
Side 4 operation shall be avoid.

Features of ST Series

ST 系列產品特點

ST

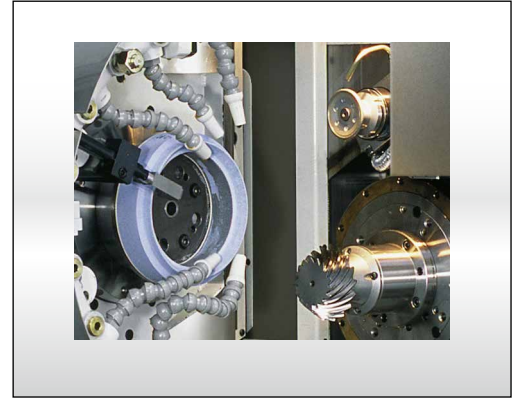
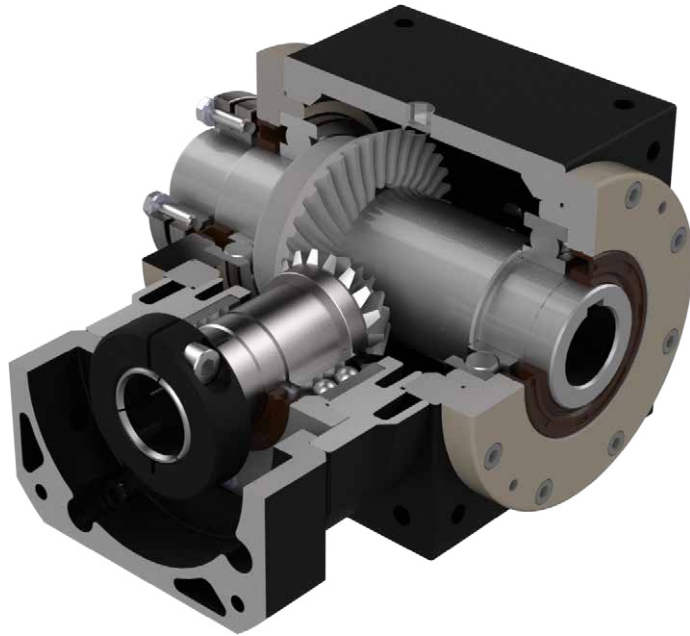

高強度、高精度螺旋傘齒輪

- 齒輪採高強力滲碳合金鋼，研磨精密度符合 AGMA12 級標準以內。

High precision grinded and carburized spiral bevel gears

- High precision grinded and carburized spiral bevel gears to meet standard AGMA12.

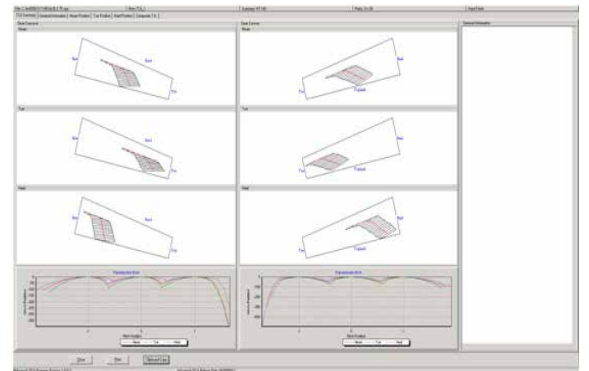
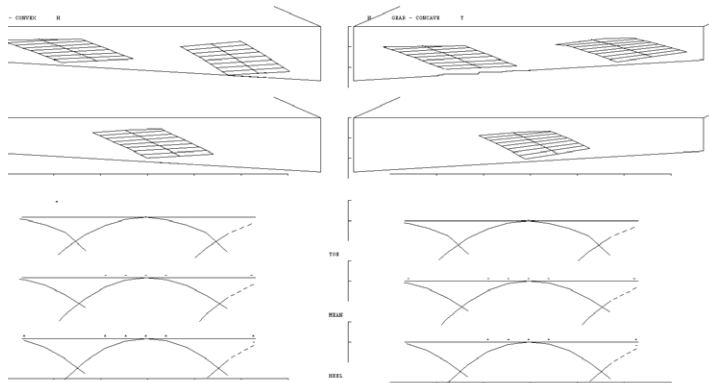

最優化的設計及 CAE 分析技術

- 採用 Gleason 參數齒輪設計軟件，得到最佳化接觸面積的齒印參數，保證了最高扭矩以及最小噪音。
- 並利用 3D-CAE 軟體的設計分析技術，對減速機整體強度及螺旋傘齒輪進行分析，增加齒輪系及減速機的使用壽命。

Optimized Design and CAE Analysis

- Use Gleason's design software to design new spiral bevel gears. Through the ideal gear contact pattern for application, achieve high permissible output torque.
- Employs 3D-CAE software for analysis and design, the software allows for analyzing the strength of the entire gear reducer and helical teeth. Increasing the service life of gears and the gear reducer.

Features of ST Series

ST 系列產品特點



低背隙

- 使用 Gleason 參數齒輪加工設備，加工研磨等級的螺旋傘齒輪，確保低背隙、低噪音。
- 背隙最小可達 2 弧分以內。

Low Backlash

- Using Gleason high precision CNC grinding machine to grinding the spiral bevel gears.
- Torsional backlash depending on design up to <2 arcmin.



安裝位置

- 多重精密加工表面易於組裝，適用於任意安裝方向。
- 入出力軸的設計可以適用於各種工業上應用的需求。

Mounting Position

- Multiple precision machined surface is easy for assembly, suitable for any optional mounting orientation.
- Output shaft and input shaft are designed to suit for various industries applications.

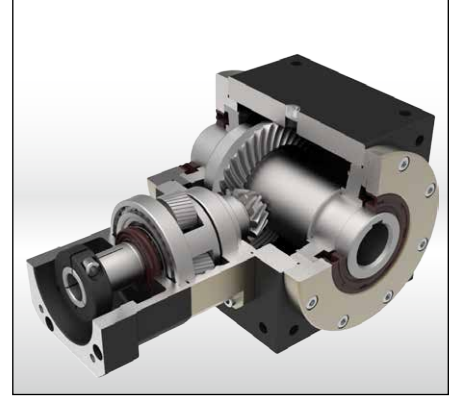

更高的減速比

- 高精密研磨的蝸線傘齒輪組結合最佳化設計的行星式齒輪組可以達到 500:1 的減速比。

More High Gear Ratio

- High precision grinded and carburized spiral bevel gears with optimal designed planetary gear can do ratio 500: 1.

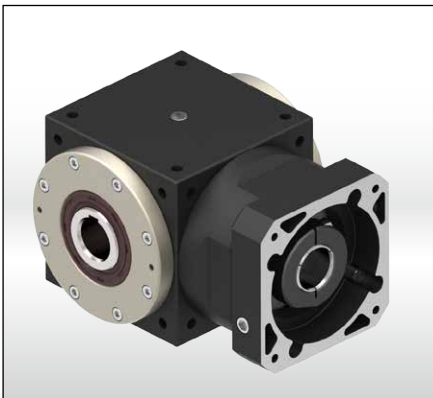

免保養

- 免保養無須更換潤滑油，運轉壽命長。

No Maintenance

- It features no maintenance and long service life.



高扭矩密度

- 一體式齒箱本體確保最大剛性與耐蝕性。
- 結構緊湊，富有剛性的設計保證了在小體積、重量輕的情況下能夠達到最高扭矩及較大的減速比。

High Output Torque

- The gear box is one-piece constructed to ensure the high rigidity and corrosion-resistant capability.

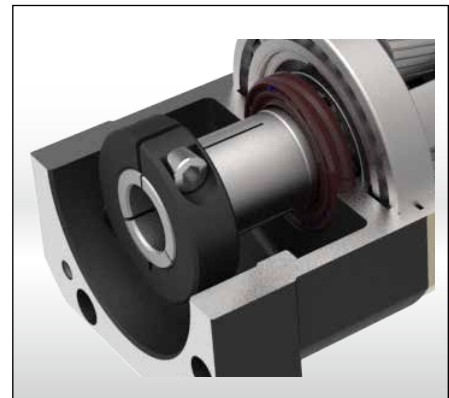

筒夾式連結機構

- 輸入端與馬達的連結採用筒夾式的鎖緊機構，並經動平衡分析，以確保在高輸入轉速下結合界面的同心度和平衡度，及零背隙的動力傳遞。

Collet Locking Mechanism

- The input-end and the motor are coupled through a collet locking mechanism. It has passed dynamical balance analysis to assure concentricity and balance on the connection and no backlash for power transmission while running at high speed.

Characteristic of ST Series

ST 系列產品特性

單段減速機 1-Stage

規格 Parameter	Code	Unit	Ratio	65	75	90	110	140	170	210	240	280
額定輸出扭矩 / Rated Output Torque (Nominal output torque)	T_{2N}	Nm	1	25	45	78	150	360	585	1,300	1,688	2,110
			2	24	42	68	150	330	544	1,220	1,510	2,666
			3	18	33	54	120	270	450	1,020	1,266	2,213
			4	13	28	52	100	224	376	860	1,048	2,026
			5	12	25	40	85	196	320	740	1,022	1,888
最大加速扭矩 / Max. Acceleration Torque	T_{2B}	Nm	1~5	1.5 倍額定輸出扭矩 1.5 Times of Rated Output Torque								
最大輸出扭矩 / Max. Output Torque 急停扭矩 / Emergency Stop Torque	T_{2NOT}	Nm	1~5	2 倍額定輸出扭矩 2 Times of Rated Output Torque								
額定輸入轉速 / Rated Input Speed	n_{1N}	rpm	1	1,000	1,000	1,000	900	900	700	700	700	700
			2	2,000	2,000	2,000	1,250	1,250	1,000	1,000	1,000	1,000
			3~5	3,000	3,000	3,000	2,500	2,500	2,000	2,000	2,000	2,000
最大輸入轉速 / Max. Input Speed	n_{1B}	rpm	1~5	6,000	6,000	5,500	4,500	3,500	3,000	3,000	3,000	3,000
背隙 / Backlash		arcmin	P0	-	≤ 3	≤ 3	≤ 3	≤ 3	≤ 3	≤ 3	≤ 3	≤ 3
			P1	≤ 6	≤ 6	≤ 6	≤ 6	≤ 6	≤ 6	≤ 6	≤ 6	≤ 6
			P2	≤ 9	≤ 9	≤ 9	≤ 9	≤ 9	≤ 9	≤ 9	≤ 9	≤ 9
容許徑向力 / Max. Radial Force 滾珠軸承 Ball Bearing	F_{2rB}	N	1~5	700	1,050	1,500	2,360	3,080	4,800	6,400	8,200	9,500
容許軸向力 / Max. Axial Force 滾珠軸承 Ball Bearing	F_{2aB}	N	1~5	350	525	750	1,180	1,540	2,400	3,200	4,100	4,750
容許徑向力 / Max. Radial Force 滾錐軸承 Taper Bearing	F_{2rB}	N	2~5	-	2,400	3,200	5,000	6,500	9,100	13,000	17,000	19,300
容許軸向力 / Max. Axial Force 滾錐軸承 Taper Bearing	F_{2aB}	N	2~5	-	1,200	1,600	2,500	3,250	4,550	6,500	8,500	9,650
使用壽命 / Service Life	L_H	hr	1~5	65#~210# : S5 周期運轉 Cycle Operation: >30,000 240#~280# : S5 周期運轉 Cycle Operation: >20,000								
效 率 / Efficiency	η	%	1~5	94% ~ 98%								
使用溫度 / Operating Temperature		°C	1~5	-10°C ~ +90°C								
潤 滑 / Lubrication			1~5	全合成潤滑油 Synthetic Oil								
噪 音 值 / Noise Level		dB	1~5	≤ 65	≤ 67	≤ 71	≤ 73	≤ 74	≤ 75	≤ 77	≤ 80	≤ 82

轉動慣量 Mass Moments of Inertia (kgcm²)

Ratio	65	75	90	110	140	170	210	240	280
1	0.51	1.79	4.93	12.5	36.8	85.9	287	428.4	668.7
2	0.44	0.95	2.78	7.41	15.6	39.3	123	250.8	526.5
3	0.43	0.78	2.34	6.18	10.9	28.5	84.1	183.5	357.0
4	0.43	0.72	2.18	5.71	9.19	24.5	69.9	157.4	309.2
5	0.43	0.69	2.10	5.48	8.32	22.6	62.7	137.4	267.7

Characteristic of ST Series

ST 系列產品特性

雙段減速機 2-Stage

規格 Parameter	Code	Unit	Ratio	65	75	90	110	140	170	210	240	280
額定輸出扭矩 / Rated Output Torque (Nominal output torque)	T_{2N}	Nm	10	24	42	68	150	330	544	1,220	1,510	2,666
			15	18	33	54	120	270	450	1,020	1,266	2,213
			20	13	28	52	100	224	376	860	1,048	2,026
			25	12	25	40	85	196	320	740	1,022	1,888
			30	18	33	54	120	270	450	1,020	1,266	2,213
			40	13	28	52	100	224	376	860	1,048	2,026
			50	12	25	40	85	196	320	740	1,022	1,888
最大加速扭矩 / Max. Acceleration Torque	T_{2B}	Nm	10~50	1.5 倍額定輸出扭矩 1.5 Times of Rated Output Torque								
最大輸出扭矩 / Max. Output Torque 急停扭矩 / Emergency Stop Torque	T_{2NOT}	Nm	10~50	2 倍額定輸出扭矩 2 Times of Rated Output Torque								
額定輸入轉速 / Rated Input Speed	n_{1N}	rpm	10~50	3,000	3,000	3,000	3,000	3,000	3,000	3,000	2,500	2,500
最大輸入轉速 / Max. Input Speed	n_{1B}	rpm	10~50	6,000	6,000	6,000	6,000	6,000	5,000	5,000	4,000	4,000
背隙 / Backlash		arcmin	P0	-	≤ 4	≤ 4	≤ 4	≤ 4	≤ 4	≤ 4	≤ 4	≤ 4
			P1	≤ 7	≤ 7	≤ 7	≤ 7	≤ 7	≤ 7	≤ 7	≤ 7	≤ 7
			P2	≤ 10	≤ 10	≤ 10	≤ 10	≤ 10	≤ 10	≤ 10	≤ 10	≤ 10
容許徑向力 / Max. Radial Force 滾珠軸承 Ball Bearing	F_{2rB}	N	10~50	700	1,050	1,500	2,360	3,080	4,800	6,400	8,200	9,500
容許軸向力 / Max. Axial Force 滾珠軸承 Ball Bearing	F_{2aB}	N	10~50	350	525	750	1,180	1,540	2,400	3,200	4,100	4,750
容許徑向力 / Max. Radial Force 滾錐軸承 Taper Bearing	F_{2rB}	N	10~50	-	2,400	3,200	5,000	6,500	9,100	13,000	17,000	19,300
容許軸向力 / Max. Axial Force 滾錐軸承 Taper Bearing	F_{2aB}	N	10~50	-	1,200	1,600	2,500	3,250	4,550	6,500	8,500	9,650
使用壽命 / Service Life	L_H	hr	10~50	65#~210# : S5 周期運轉 Cycle Operation: >30,000 240#~280# : S5 周期運轉 Cycle Operation: >20,000								
效率 / Efficiency	η	%	10~50	90% ~ 94%								
使用溫度 / Operating Temperature		°C	10~50	-10°C ~ +90°C								
潤滑 / Lubrication			10~50	全合成潤滑油 Synthetic Oil								
噪音值 / Noise Level		dB	10~50	≤ 68	≤ 69	≤ 73	≤ 74	≤ 75	≤ 76	≤ 78	≤ 82	≤ 84

轉動慣量 Mass Moments of Inertia (kgcm²)

Ratio	65	75	90	110	140	170	210	240	280
10	0.05	0.15	0.18	0.41	0.56	3.25	8.9	23.29	53.27
15	0.05	0.15	0.18	0.41	0.56	3.25	8.9	23.29	53.27
20	0.05	0.15	0.18	0.41	0.56	3.25	8.9	23.29	53.27
25	0.05	0.15	0.18	0.41	0.56	3.25	8.9	23.29	53.27
30	0.05	0.15	0.16	0.38	0.53	3.09	8.4	22.51	50.56
40	0.05	0.15	0.16	0.38	0.53	3.09	8.4	22.51	50.56
50	0.05	0.15	0.16	0.38	0.53	3.09	8.4	22.51	50.56

ST-FO series

RATIO : 1.2.3.4.5 (單段 1-Stage)

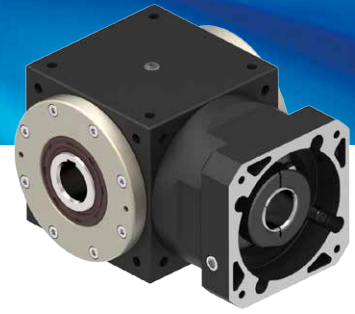

入力法蘭 - 出力中空軸

Input Flange - Hollow Output Shaft

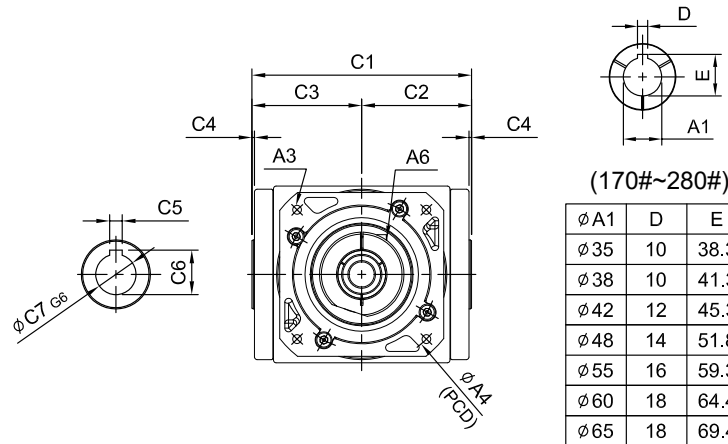
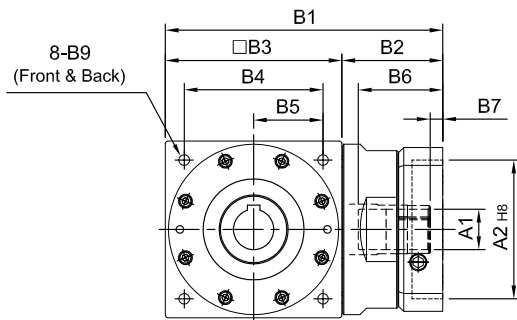
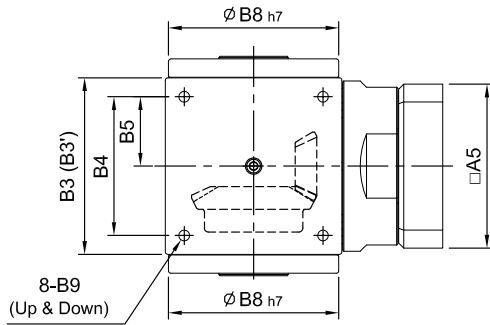

(170#~280#)

$\phi A1$	D	E
$\phi 35$	10	38.3
$\phi 38$	10	41.3
$\phi 42$	12	45.3
$\phi 48$	14	51.8
$\phi 55$	16	59.3
$\phi 60$	18	64.4
$\phi 65$	18	69.4

unit: mm

Model Code	65	65 (1:1)	75	90	110	140	170	210	240	280
A	A1	9 · 11 · 14	14 · 19	16 · 19 · 22 · 24	19 · 22 · 24	24 · 28 · 32 · 35	35 · 38	35 · 38 · 42 · 48 · 55	48 · 55 · 60	55 · 60 · 65
	A2	50 · 60 · 70	50 · 60 · 70	70 · 80 · 95 · 110	70 · 80 · 95 · 110	95 · 110 · 130	110 · 130 · 180	114.3 · 180 · 230	114.3 · 230 · 250	114.3 · 180 · 230 · 250
	A3	M4 · M5 · M6	M4 · M5 · M6	M5 · M6 · M8	M5 · M6 · M8	M6 · M8 · M10	M8 · M10 · M12	M10 · M12 · M16	M12 · M16	M12 · M16
	A4	70 · 75 · 90	70 · 75 · 90	90 · 100 · 115 · 145	90 · 100 · 115 · 145	115 · 145 · 165	145 · 165 · 200	200 · 215 · 265	200 · 265 · 300	200 · 215 · 265 · 300
	A5	64 · 70 · 80	64 · 70 · 80	92 · 110 · 130	92 · 110 · 130	122 · 130 · 150	146 · 150 · 190	182 · 200 · 250	222 · 250 · 265	222 · 220 · 250 · 265
	A6	M5 x P0.8	M5 x P0.8	M6 x P1.0	M6 x P1.0	M8 x P1.25	M10 x P1.5	M10 x P1.5	M10 x P1.5	M10 x P1.5
B	B1	110	115 · 124	148 · 162	177 · 191	224 · 238	274	357 · 359	394.5 · 421.5 · 424.5	453.5 · 483
	B2	45	40 · 49	58 · 72	67 · 81	84 · 98	104	147	154.5 · 181.5 · 184.5	173.5 · 203
	B3(B3')	65	75(74)	90	110	140	170(168)	210	240	280
	B4	52	60	72	88	110	134	170	190	220
	B5	26	30	36	44	55	67	85	95	110
	B6	36	36 · 42	51 · 65.5	51 · 65.5	68 · 81	84.5	117 · 119	115 · 142 · 145	112.5 · 142
	B7	7	7	9 · 23.5	9 · 23.5	9 · 10	9.5	14 · 16	12.5 · 15.5	12.5 · 42
	B8	62 64	73	88	106	135	164	205	228	275
B9	M5 x P0.8	M6 x P1.0	M6 x P1.0	M8 x P1.25	M10 x P1.5	M12 x P1.75	M16 x P2.0	M16 x P2.0	M16 x P2.0	M16 x P2.0
C	C1	84 89	100	118	144	174	204	250	292	328
	C2	42 44.5	50	59	72	87	102	125	146	164
	C3	42 44.5	50	59	72	87	102	125	146	164
	C4	2	2	2	2	2	2	2	2	3
	C5	5	5	6	6	10	12	14	16	18
	C6	16.3	16.3	20.8	24.8	35.3	43.3	53.8	59.3	64.4
	C7	14	14	18	22	32	40	50	55	60
Weight ±3% (kg)	1.7	2.4	4.3	7.1	14.9	24.5	46	60.7		

ST-RO series

RATIO : 10.15.20.25.30.40.50 (雙段 2-Stage)

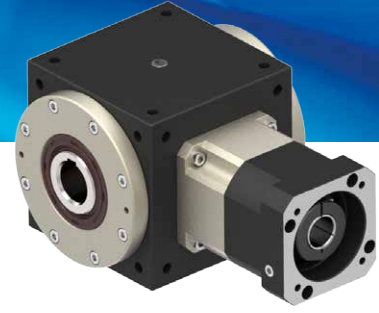

搭配行星減速機 - 出力中空軸

Fitted with Planetary Reducer - Hollow Output Shaft

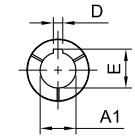
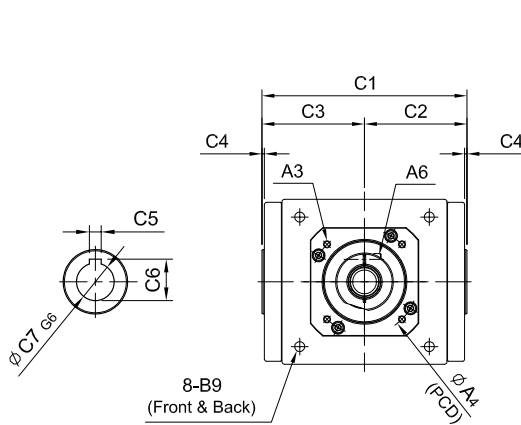
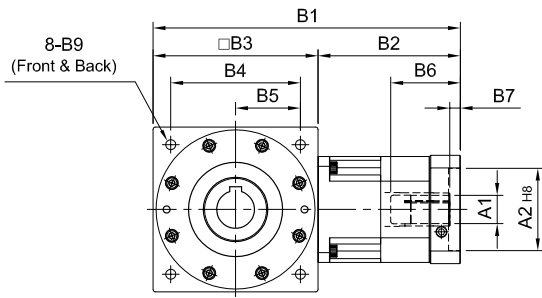
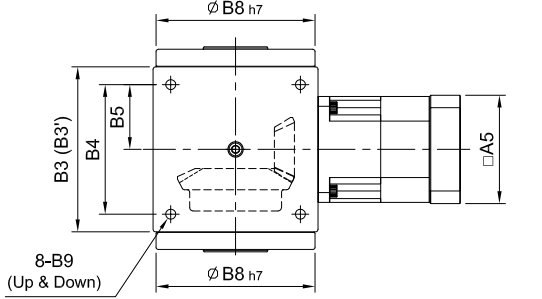

(210#~280#)

ØA1	D	E
Ø28	8	31.3
Ø32	10	35.3
Ø35	10	38.3
Ø38	10	41.3
Ø42	12	45.3
Ø48	14	51.8
Ø55	16	59.3

unit: mm

Model Code	65	75	90	110	140	170	210	240	280		
A	A1	8 · 9 · 11	8 · 9 · 11	11 · 14 · 16 19	11 · 14 · 16 · 19	(14) · 16 · 19	16 · 19 · 22 · 24	22 · 24 · 28 · 32 · 35	28 · 32 · 35 · 38	35 · 38 · 42 · 48 · 55	38 · 42 · 48 · 55
	A2	30 · 40 · 50	30 · 40 · 50	50 · 60 · 70	50 · 60 · 70	50 · 70 · 80 · 95	70 · 80 · 95 · 110	95 · 110 · 130	110 · 130 · 180	114.3 · 180 · 230 · 250	114.3 · 180 · 230 · 250
	A3	M3 · M4 · M5	M3 · M4 · M5	M4 · M5 · M6	M4 · M5 · M6	M5 · M6	M5 · M6 · M8	M6 · M8 · M10	M8 · M10 · M12	M10 · M12 · M16	M12 · M16
	A4	46 · 60 · 63	46 · 60 · 63	70 · 75 · 90	70 · 75 · 90	70 · 90 · 100 · 115	90 · 100 · 115 · 145	115 · 145 · 165	145 · 165 · 200	200 · 215 · 265 · 300	200 · 215 · 265 · 300
	A5	46 · 55	46 · 55	64 · 70 · 80	64 · 70 · 80	80 · 92 · 110	92 · 110 · 130	122 · 130 · 150	146 · 150 · 190	182 · 200 · 250 · 265	222 · 220 · 250 · 265
	A6	M4 x P0.7	M4 x P0.7	M5 x P0.8	M5 x P0.8	M5 x P0.8	M6 x P1.0	M8 x P1.25	M10 x P1.5	M10 x P1.5	M10 x P1.5
B	B1	132	137	149 · 157	165 · 173	(191) · 203	260	313 · 334	399	479.5	580.5
	B2	67	62	74 · 82	75 · 83	(81) · 93	120	143 · 164	189	239.5	300.5
	B3(B3')	65	75(74)	75(74)	90	110	140	170(168)	210	240	280
	B4	52	60	60	72	88	110	134	170	190	220
	B5	26	30	30	36	44	55	67	85	95	110
	B6	26	26	33.5 · 41.5	33.5 · 41.5	(33.5) · 45.5	59	67 · 83	85	116.5	117.5
	B7	5	5	6	6	(6) · 10	9	10 · 11	10	13.5	12.5
	B8	62	73	73	88	106	135	164	205	228	275
B9	M5 x P0.8	M6 x P1.0	M6 x P1.0	M6 x P1.0	M8 x P1.25	M10 x P1.5	M12 x P1.75	M16 x P2.0	M16 x P2.0	M16 x P2.0	
C	C1	84	100	100	118	144	174	204	250	292	328
	C2	42	50	50	59	72	87	102	125	146	164
	C3	42	50	50	59	72	87	102	125	146	164
	C4	2	2	2	2	2	2	2	2	2	3
	C5	5	5	5	6	6	10	12	14	16	18
	C6	16.3	16.3	16.3	20.8	24.8	35.3	43.3	53.8	59.3	64.4
	C7	14	14	14	18	22	32	40	50	55	60
Weight ±3% (kg)	1.9	3.6	3.4	4.8	8.5	14.2	24	52	73.7	117.7	

ST-DO series

RATIO : 1.2.3.4.5 (單段 1-Stage)

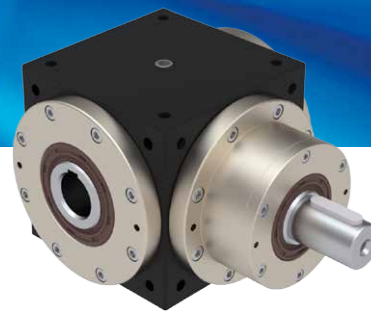

單入力軸心 - 出力中空軸

Single Input Shaft - Hollow Output Shaft

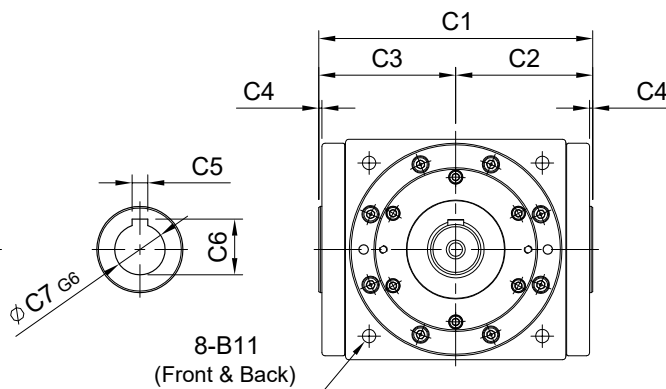
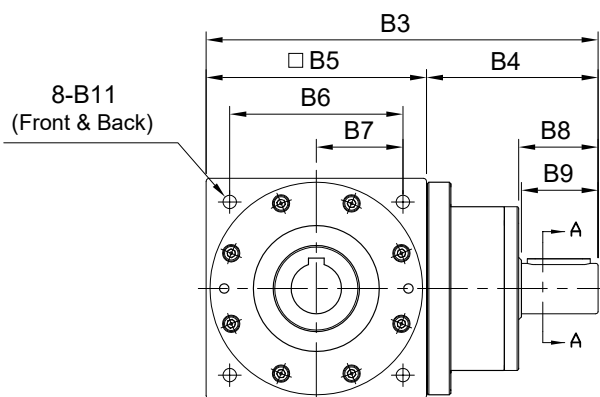
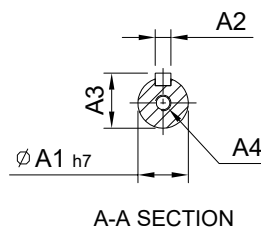
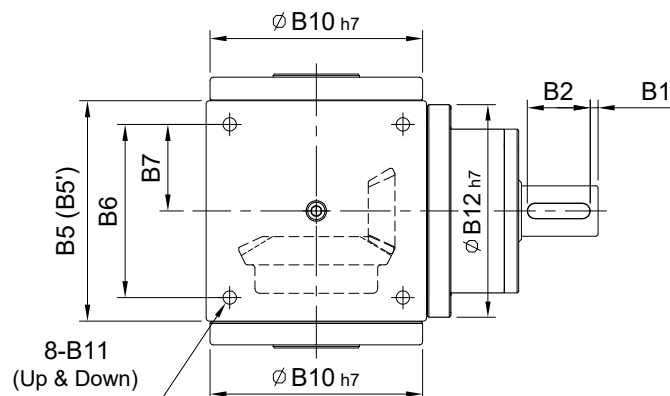

unit: mm

Model Code	65	65 (1:1)	75	90	110	140	170	210	240	280
	A	A1	14	16	18	22	32	40	50	55
	A2	5	5	6	6	10	12	14	16	18
	A3	16	18	20.5	24.5	35	43	53.5	59	64
	A4	M5 x P0.8	M5 x P0.8	M8 x P1.25	M8 x P1.25	M10 x P1.5	M12 x P1.75	M12 x P1.75	M16 x P2.0	M16 x P2.0
B	B1	2.5	2.5	5	5	5	5	5	5	5
	B2	15	25	25	30	40	50	65	70	90
	B3	127.5	143	168.5	207	250	300	375	430	505
	B4	62.5	68	78.5	97	110	130	165	190	225
	B5(B5')	65	75(74)	90	110	140	170(168)	210	240	280
	B6	52	60	72	88	110	134	170	190	220
	B7	26	30	36	44	55	67	85	95	110
	B8	22	32	38	43	53.5	64	77	82	105
	B9	20	30	35	40	50	60	75	80	100
	B10	62	64	73	88	106	135	164	205	228
	B11	M5 x P0.8	M6 x P1.0	M6 x P1.0	M8 x P1.25	M10 x P1.5	M12 x P1.75	M16 x P2.0	M16 x P2.0	M16 x P2.0
	B12	-	73	88	106	135	164	205	228	219
C	C1	84	89	100	118	144	204	250	292	328
	C2	42	44.5	50	59	72	87	125	146	164
	C3	42	44.5	50	59	72	87	102	146	164
	C4	2	2	2	2	2	2	2	2	3
	C5	5	5	6	6	10	12	14	16	18
	C6	16.3	16.3	20.8	24.8	35.3	43.3	53.8	59.3	64.4
	C7	14	14	18	22	32	40	50	55	60
Weight ±3% (kg)		2.1	2.8	4.9	9	15.5	25	53	73.4	

ST-YO series

RATIO : 1.2.3.4.5 (單段 1-Stage)

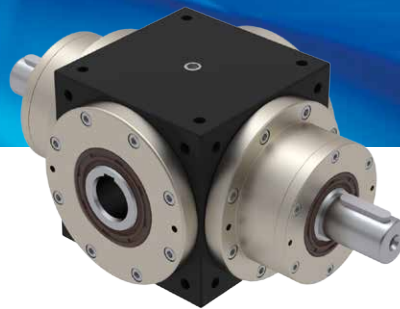

雙入力軸心 - 出力中空軸

Double Input Shaft - Hollow Output Shaft

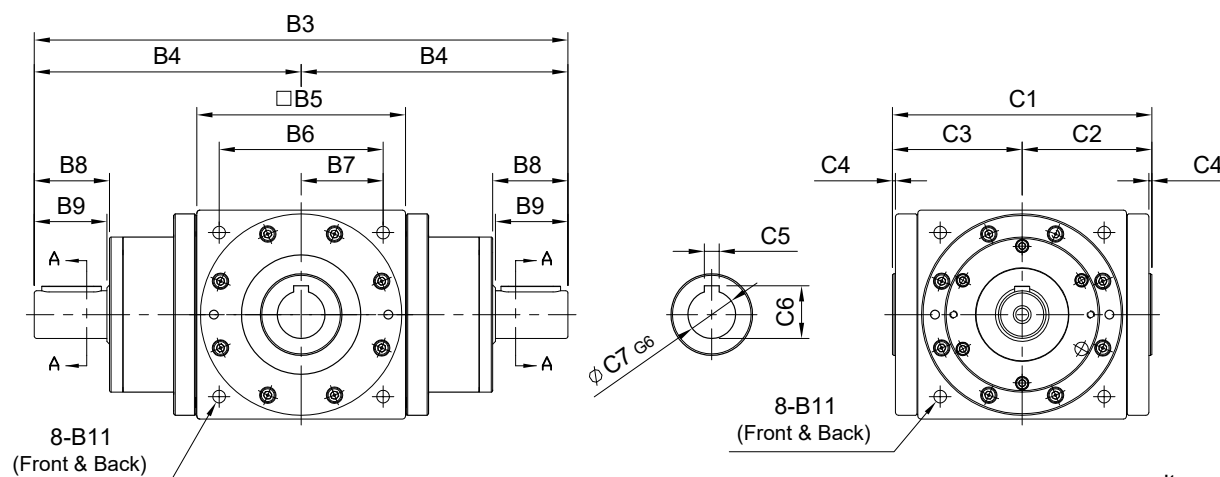
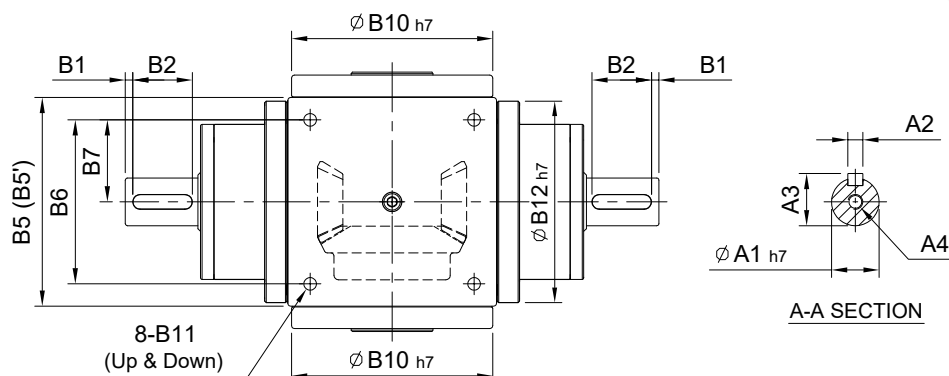

unit: mm

	Model Code	65	65 (1:1)	75	90	110	140	170	210	240	280
		A	A1	14	16	18	22	32	40	50	55
	A2	5	5	6	6	10	12	14	16	18	
	A3	16	18	20.5	24.5	35	43	53.5	59	64	
	A4	M5 x P0.8	M5 x P0.8	M8 x P1.25	M8 x P1.25	M10 x P1.5	M12 x P1.75	M12 x P1.75	M16 x P2.0	M16 x P2.0	
B	B1	2.5	2.5	5	5	5	5	5	5	5	
	B2	15	25	25	30	40	50	65	70	90	
	B3	190	210	247	304	360	430	540	620	730	
	B4	95	105	123.5	152	180	215	270	310	365	
	B5(B5')	65	75(74)	90	110	140	170(168)	210	240	280	
	B6	52	60	72	88	110	134	170	190	220	
	B7	26	30	36	44	55	67	85	95	110	
	B8	22	32	38	43	53.5	64	77	82	105	
	B9	20	30	35	40	50	60	75	80	100	
	B10	62 64	73	88	106	135	164	205	228	275	
	B11	M5 x P0.8	M6 x P1.0	M6 x P1.0	M8 x P1.25	M10 x P1.5	M12 x P1.75	M16 x P2.0	M16 x P2.0	M16 x P2.0	
	B12	-	73	88	106	135	164	205	228	219	
C	C1	84 89	100	118	144	174	204	250	292	328	
	C2	42 44.5	50	59	72	87	102	125	146	164	
	C3	42 44.5	50	59	72	87	102	125	146	164	
	C4	2	2	2	2	2	2	2	2	3	
	C5	5	5	6	6	10	12	14	16	18	
	C6	16.3	16.3	20.8	24.8	35.3	43.3	53.8	59.3	64.4	
	C7	14	14	18	22	32	40	50	55	60	
Weight ±3% (kg)		2.85	3.6	6.2	11.5	18	28	57	95		

ST-FN series

RATIO : 1.2.3.4.5 (單段 1-Stage)



入力法蘭 - 單邊免鍵軸套

Input Flange - Single Clamping

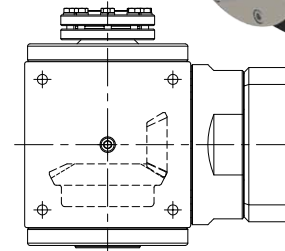
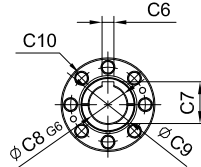
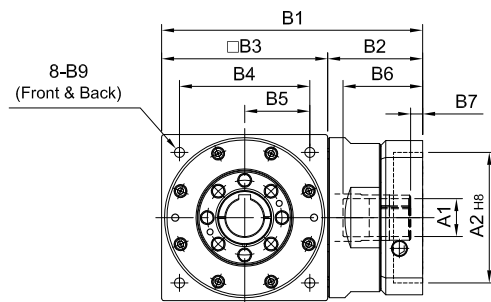
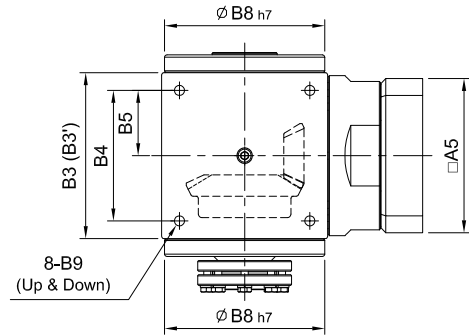

R 軸
Shaft Direction

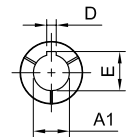
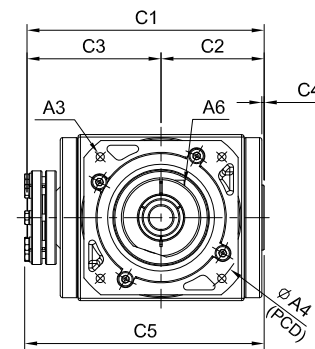

(170#~280#)

$\phi A1$	D	E
$\phi 35$	10	38.3
$\phi 38$	10	41.3
$\phi 42$	12	45.3
$\phi 48$	14	51.8
$\phi 55$	16	59.3
$\phi 60$	18	64.4
$\phi 65$	18	69.4

unit: mm

Model Code	65	65 (1:1)	75	90	110	140	170	210	240	280
A	A1	9 · 11 · 14	14 · 19	16 · 19 · 22 · 24	19 · 22 · 24	24 · 28 · 32 · 35	35 · 38	35 · 38 · 42 · 48 · 55	48 · 55 · 60	55 · 60 · 65
	A2	50 · 60 · 70	50 · 60 · 70	70 · 80 · 95 · 110	70 · 80 · 95 · 110	95 · 110 · 130	110 · 130 · 180	114.3 · 180 · 230	114.3 · 230 · 250	114.3 · 180 · 230 · 250
	A3	M4 · M5 · M6	M4 · M5 · M6	M5 · M6 · M8	M5 · M6 · M8	M6 · M8 · M10	M8 · M10 · M12	M10 · M12 · M16	M12 · M16	M12 · M16
	A4	70 · 75 · 90	70 · 75 · 90	90 · 100 · 115 · 145	90 · 100 · 115 · 145	115 · 145 · 165	145 · 165 · 200	200 · 215 · 265	200 · 265 · 300	200 · 215 · 265 · 300
	A5	64 · 70 · 80	64 · 70 · 80	92 · 110 · 130	92 · 110 · 130	122 · 130 · 150	146 · 150 · 190	182 · 200 · 250	222 · 250 · 265	222 · 220 · 250 · 265
	A6	M5 x P0.8	M5 x P0.8	M6 x P1.0	M6 x P1.0	M8 x P1.25	M10 x P1.5	M10 x P1.5	M10 x P1.5	M10 x P1.5
B	B1	110	115 · 124	148 · 162	177 · 191	224 · 238	274	357 · 359	394.5 · 421.5 · 424.5	453.5 · 483
	B2	45	40 · 49	58 · 72	67 · 81	84 · 98	104	147	154.5 · 181.5 · 184.5	173.5 · 203
	B3(B3')	65	75(74)	90	110	140	170(168)	210	240	280
	B4	52	60	72	88	110	134	170	190	220
	B5	26	30	36	44	55	67	85	95	110
	B6	36	36 · 42	51 · 65.5	51 · 65.5	68 · 81	84.5	117	115 · 142 · 145	112.5 · 142
	B7	7	7	9 · 23.5	9 · 23.5	9 · 10	9.5	14 · 16	12.5 · 15.5	12.5 · 42
	B8	62 64	73	88	106	135	164	205	228	275
B9	M5 x P0.8	M6 x P1.0	M6 x P1.0	M8 x P1.25	M10 x P1.5	M12 x P1.75	M16 x P2.0	M16 x P2.0	M16 x P2.0	M16 x P2.0
C	C1	104 109	120	138	169	202	240	285	324	370
	C2	42 44.5	50	59	72	87	102	125	146	164
	C3	62 64.5	70	79	97	115	138	160	178	206
	C4	2	2	2	2	2	2	2	2	3
	C5	110 113	124	142	171	202	242	288	329	369.8
	C6	5	5	6	6	10	12	14	16	18
	C7	16.3	16.3	20.8	24.8	35.3	43.3	53.8	59.3	64.4
	C8	14	14	18	22	32	40	50	55	60
	C9	22	22	28	34	44	52	65	73	83
	C10	6-M6	6-M6	6-M6	8-M6	8-M6	8-M8	8-M8	8-M8	8-M8
Weight ±3% (kg)	1.7	2.4	4.3	7.1	14.9	24.5	46	61.2		

ST-RN series

RATIO : 10.15.20.25.30.40.50 (雙段 2-Stage)



搭配行星減速機 - 單邊免鍵軸套

Fitted with Planetary Reducer - Single Clamping

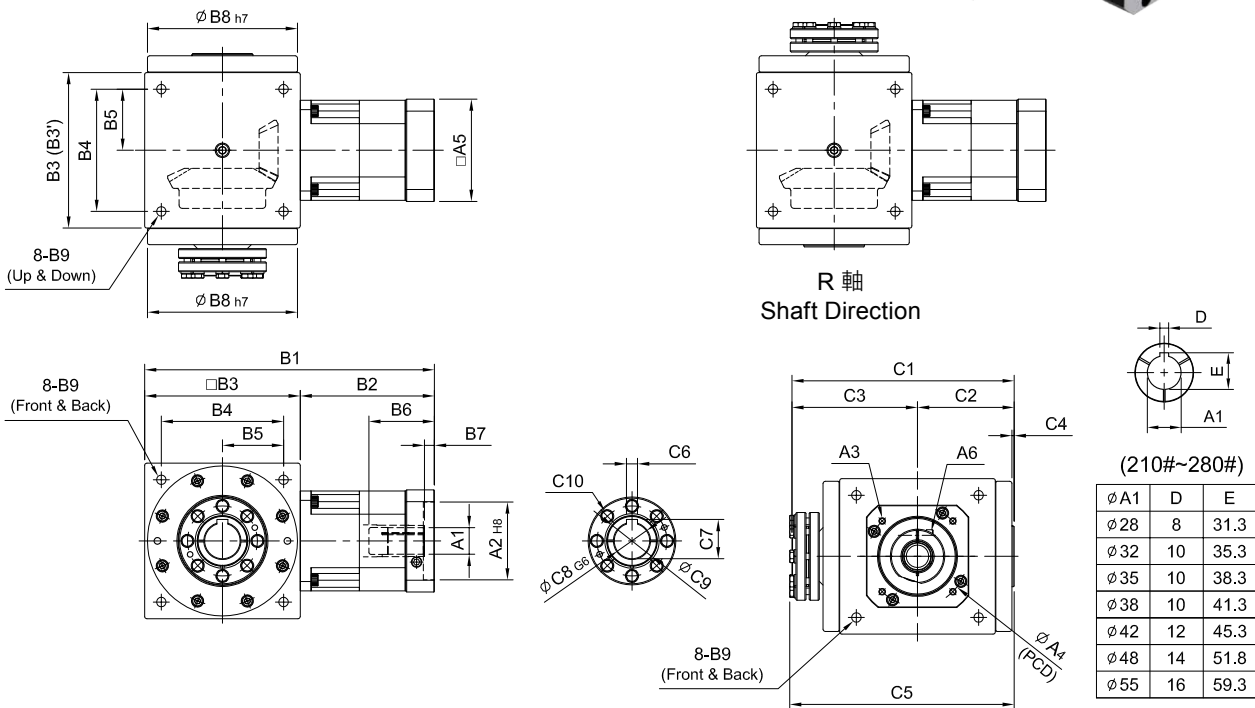

unit: mm

Model Code	65	75	90	110	140	170	210	240	280		
A	A1	8·9·11	8·9·11	11·14·16·19	11·14·16·19	(14)·16·19	16·19·22·24	22·24·28·32·35	28·32·35·38	35·38·42·48·55	
	A2	30·40·50	30·40·50	50·60·70	50·60·70	50·70·80·95	70·80·95·110	95·110·130	110·130·180	114.3·180·230·250	
	A3	M3·M4·M5	M3·M4·M5	M4·M5·M6	M4·M5·M6	M5·M6	M5·M6·M8	M6·M8·M10	M8·M10·M12	M10·M12·M16	M12·M16
	A4	46·60·63	46·60·63	70·75·90	70·75·90	70·90·100·115	90·100·115·145	115·145·165	145·165·200	200·215·265·300	200·215·265·300
	A5	46·55	46·55	64·70·80	64·70·80	80·92·110	92·110·130	122·130·150	146·150·190	182·200·250·265	222·220·250·265
	A6	M4 x P0.7	M4 x P0.7	M5 x P0.8	M5 x P0.8	M5 x P0.8	M6 x P1.0	M8 x P1.25	M10 x P1.5	M10 x P1.5	M10 x P1.5
B	B1	132	137	149·157	165·173	(191)·203	260	313·334	399	479.5	580.5
	B2	67	62	74·82	75·83	(81)·93	120	143·164	189	239.5	300.5
	B3(B3')	65	75(74)	75(74)	90	110	140	170(168)	210	240	280
	B4	52	60	60	72	88	110	134	170	190	220
	B5	26	30	30	36	44	55	67	85	95	110
	B6	26	26	33.5·41.5	33.5·41.5	(33.5)·45.5	59	67·83	85	116.5	117.5
	B7	5	5	6	6	(6)·10	9	10·11	10	13.5	12.5
	B8	62	73	73	88	106	135	164	205	228	275
B9	M5 x P0.8	M6 x P1.0	M6 x P1.0	M6 x P1.0	M8 x P1.25	M10 x P1.5	M12 x P1.75	M16 x P2.0	M16 x P2.0	M16 x P2.0	
C	C1	104	120	120	138	169	200	240	285	324	370
	C2	42	50	50	59	72	87	102	125	146	164
	C3	62	70	70	79	97	113	138	160	178	206
	C4	2	2	2	2	2	2	2	2	2	3
	C5	118	124	124	142	171	202	242	288	329	369.8
	C6	5	5	5	6	6	10	12	14	16	18
	C7	16.3	16.3	16.3	20.8	24.8	35.3	43.3	53.8	59.3	64.4
	C8	14	14	14	18	22	32	40	50	55	60
	C9	22	22	22	28	34	44	52	65	73	83
	C10	6-M6	6-M6	6-M6	6-M6	8-M6	8-M6	8-M8	8-M8	8-M8	8-M10
Weight ±3% (kg)	1.9	3.6	3.4	4.8	8.5	14.2	24	52	74.2		

ST-DN series

RATIO : 1.2.3.4.5 (單段 1-Stage)



單入力軸心 - 單邊免鍵軸套

Single Input Shaft - Single Clamping

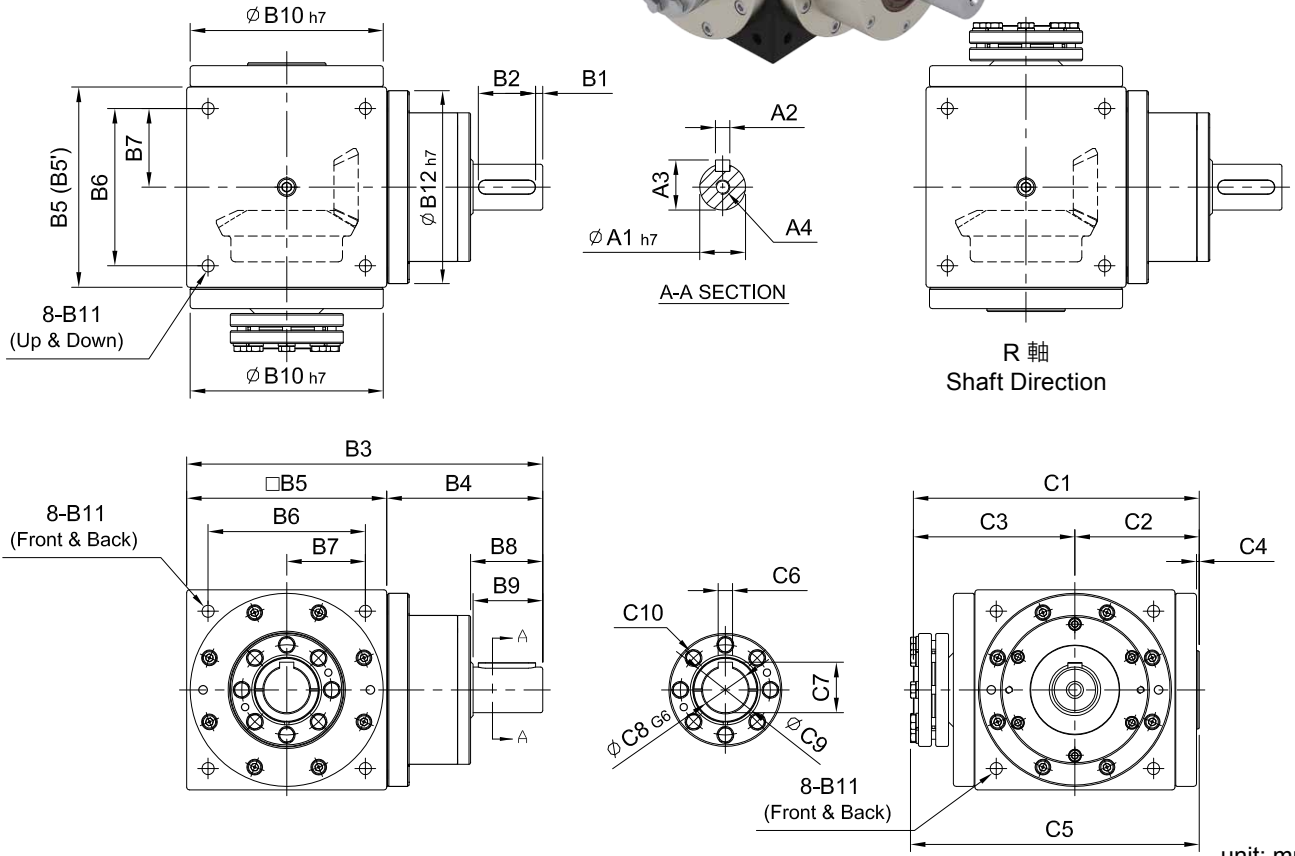

unit: mm

Model Code	65	65 (1:1)	75	90	110	140	170	210	240	280	
	A	A1	14	16	18	22	32	40	50	55	60
	A2	5	5	6	6	10	12	14	16	18	
	A3	16	18	20.5	24.5	35	43	53.5	59	64	
	A4	M5 x P0.8	M5 x P0.8	M8 x P1.25	M8 x P1.25	M10 x P1.5	M12 x P1.75	M12 x P1.75	M16 x P2.0	M16 x P2.0	
B	B1	2.5	2.5	5	5	5	5	5	5	5	
	B2	15	25	25	30	40	50	65	70	90	
	B3	127.5	143	168.5	207	250	300	375	430	505	
	B4	62.5	68	78.5	97	110	130	165	190	225	
	B5(B5')	65	75(74)	90	110	140	170(168)	210	240	280	
	B6	52	60	72	88	110	134	170	190	220	
	B7	26	30	36	44	55	67	85	95	110	
	B8	22	32	38	43	53.5	64	77	82	105	
	B9	20	30	35	40	50	60	75	80	100	
	B10	62	64	73	88	106	135	164	205	228	275
	B11	M5 x P0.8	M6 x P1.0	M6 x P1.0	M8 x P1.25	M10 x P1.5	M12 x P1.75	M16 x P2.0	M16 x P2.0	M16 x P2.0	
	B12	-	73	88	106	135	164	205	228	219	
C	C1	104	109	120	138	169	202	240	285	324	370
	C2	42	44.5	50	59	72	87	102	125	146	164
	C3	62	64.5	70	79	97	115	138	160	178	206
	C4	2	2	2	2	2	2	2	2	2	3
	C5	110	113	124	142	171	202	242	288	329	369.8
	C6	5	5	6	6	10	12	14	16	18	
	C7	16.3	16.3	20.8	24.8	35.3	43.3	53.8	59.3	64.4	
	C8	14	14	18	22	32	40	50	55	60	
	C9	22	22	28	34	44	52	65	73	83	
	C10	6-M6	6-M6	6-M6	8-M6	8-M6	8-M8	8-M8	8-M8	8-M8	8-M10
Weight $\pm 3\%$ (kg)	2.1	2.8	4.9	8.59	15.5	25	53	73.9			

ST-YN series

RATIO : 1.2.3.4.5 (單段 1-Stage)

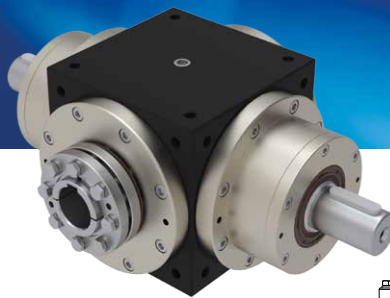

雙入力軸心 - 單邊免鍵軸套

Double Input Shaft - Single Clamping

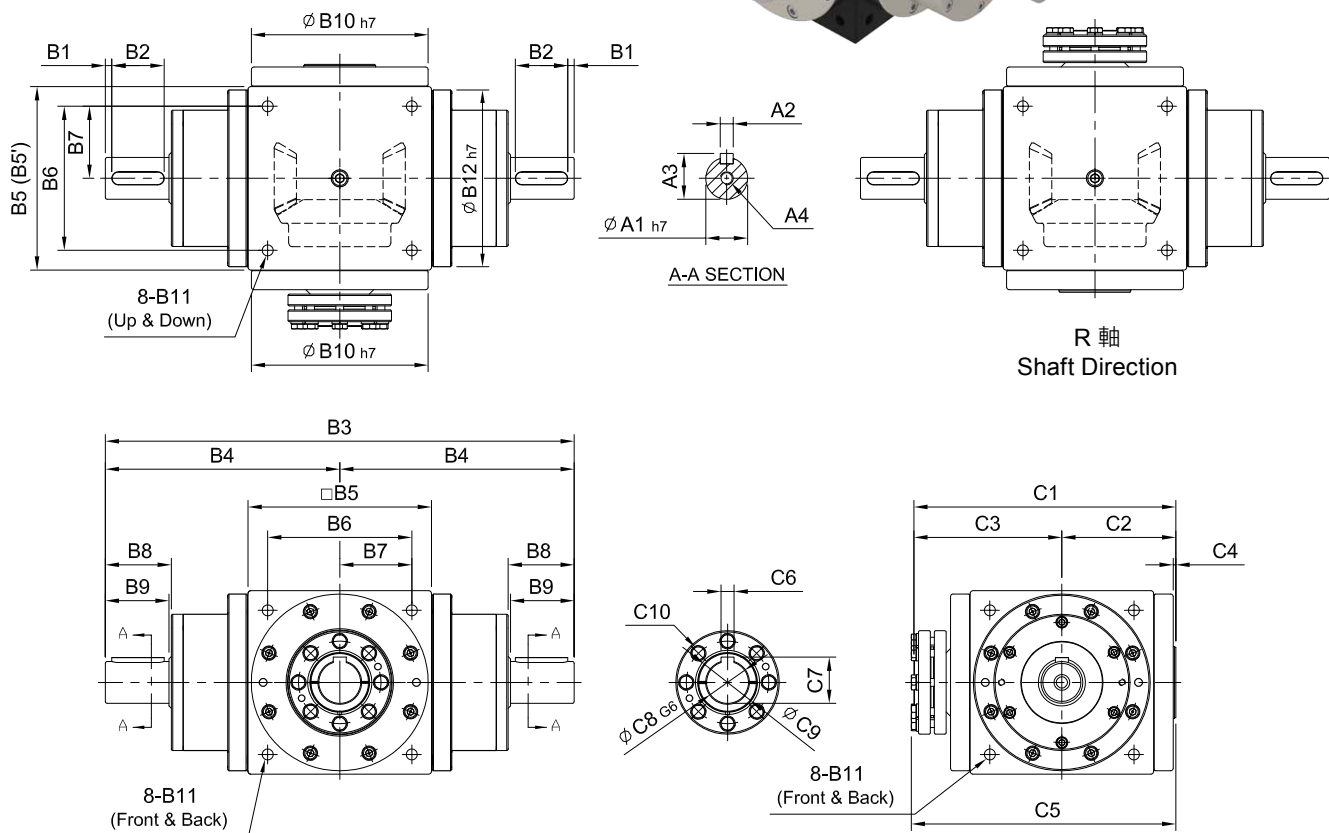

unit: mm

Model Code	65	65 (1:1)	75	90	110	140	170	210	240	280	
	A	A1	14	16	18	22	32	40	50	55	60
	A2	5	5	6	6	10	12	14	16	18	
	A3	16	18	20.5	24.5	35	43	53.5	59	64	
	A4	M5 x P0.8	M5 x P0.8	M8 x P1.25	M8 x P1.25	M10 x P1.5	M12 x P1.75	M12 x P1.75	M16 x P2.0	M16 x P2.0	
B	B1	2.5	2.5	5	5	5	5	5	5	5	
	B2	15	25	25	30	40	50	65	70	90	
	B3	190	210	247	304	360	430	540	620	730	
	B4	95	105	123.5	152	180	215	270	310	365	
	B5(B5')	65	75(74)	90	110	140	170(168)	210	240	280	
	B6	52	60	72	88	110	134	170	190	220	
	B7	26	30	36	44	55	67	85	95	110	
	B8	22	32	38	43	53.5	64	77	82	105	
	B9	20	30	35	40	50	60	75	80	100	
	B10	62	64	73	88	106	135	164	205	228	275
	B11	M5 x P0.8	M6 x P1.0	M6 x P1.0	M8 x P1.25	M10 x P1.5	M12 x P1.75	M16 x P2.0	M16 x P2.0	M16 x P2.0	
	B12	-	73	88	106	135	164	205	228	219	
C	C1	104	109	120	138	169	200	285	324	370	
	C2	42	44.5	50	59	72	87	102	146	164	
	C3	62	64.5	70	79	97	113	138	178	206	
	C4	2	2	2	2	2	2	2	2	3	
	C5	110	113	124	142	171	202	242	288	329	369.8
	C6	5	5	6	6	10	12	14	16	18	
	C7	16.3	16.3	20.8	24.8	35.3	43.3	53.8	59.3	64.4	
	C8	14	14	18	22	32	40	50	55	60	
	C9	22	22	28	34	44	52	65	73	83	
	C10	6-M6	6-M6	6-M6	8-M6	8-M6	8-M8	8-M8	8-M8	8-M8	8-M10
Weight $\pm 3\%$ (kg)	2.85	3.6	6.2	11.5	18	28	57	95.5			

ST-FM series

RATIO : 1.2.3.4.5 (單段 1-Stage)



入力法蘭 - 雙邊免鍵軸套

Input Flange - Double Clamping

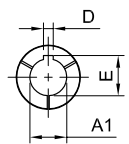
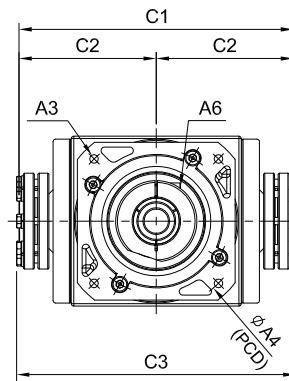
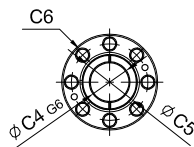
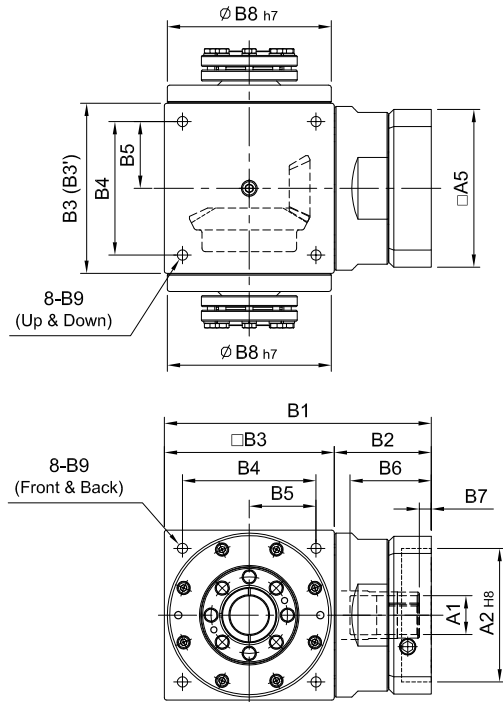

(170#~280#)

∅A1	D	E
∅35	10	38.3
∅38	10	41.3
∅42	12	45.3
∅48	14	51.8
∅55	16	59.3
∅60	18	64.4
∅65	18	69.4

unit: mm

	Model Code	65		75	90	110	140	170	210	240	280
		65	65 (1:1)	75	90	110	140	170	210	240	280
A	A1	9 · 11 · 14		14 · 19	16 · 19 · 22 · 24	19 · 22 · 24	24 · 28 · 32 · 35	35 · 38	35 · 38 · 42 · 48 · 55	48 · 55 · 60	55 · 60 · 65
	A2	50 · 60 · 70		50 · 60 · 70	70 · 80 · 95 · 110	70 · 80 · 95 · 110	95 · 110 · 130	110 · 130 · 180	114.3 · 180 · 230	114.3 · 230 · 250	114.3 · 180 · 230 · 250
	A3	M4 · M5 · M6		M4 · M5 · M6	M5 · M6 · M8	M5 · M6 · M8	M6 · M8 · M10	M8 · M10 · M12	M10 · M12 · M16	M12 · M16	M12 · M16
	A4	70 · 75 · 90		70 · 75 · 90	90 · 100 · 115 · 145	90 · 100 · 115 · 145	115 · 145 · 165	145 · 165 · 200	200 · 215 · 265	200 · 265 · 300	200 · 215 · 265 · 300
	A5	64 · 70 · 80		64 · 70 · 80	92 · 110 · 130	92 · 110 · 130	122 · 130 · 150	146 · 150 · 190	182 · 200 · 250	222 · 250 · 265	222 · 220 · 250 · 265
	A6	M5 x P0.8		M5 x P0.8	M6 x P1.0	M6 x P1.0	M8 x P1.25	M10 x P1.5	M10 x P1.5	M10 x P1.5	M10 x P1.5
B	B1	110		115 · 124	148 · 162	177 · 191	224 · 238	274	357 · 359	394.5 · 21.5 · 424.5	453.5 · 483
	B2	45		40 · 49	58 · 72	67 · 81	84 · 98	104	147	154.5 · 181.5 · 184.5	173.5 · 203
	B3(B3')	65		75(74)	90	110	140	170(168)	210	240	280
	B4	52		60	72	88	110	134	170	190	220
	B5	26		30	36	44	55	67	85	95	110
	B6	36		36 · 42	51 · 65.5	51 · 65.5	68 · 81	84.5	117	115 · 142 · 145	112.5 · 142
	B7	7		7	9 · 23.5	9 · 23.5	9 · 10	9.5	14 · 16	12.5 · 15.5	12.5 · 42
	B8	62	64	73	88	106	135	164	205	228	275
B9	M5 x P0.8		M6 x P1.0	M6 x P1.0	M8 x P1.25	M10 x P1.5	M12 x P1.75	M16 x P2.0	M16 x P2.0	M16 x P2.0	M16 x P2.0
C	C1	124	129	140	158	194	230	276	320	356	412
	C2	62	64.5	70	79	97	115	138	160	178	206
	C3	136	138	150	166	198	232	280	327	370	411.7
	C4	14		14	18	22	32	40	50	55	60
	C5	22		22	28	34	44	52	65	73	83
	C6	6-M6		6-M6	6-M6	8-M6	8-M6	8-M6	8-M8	8-M8	8-M8
Weight ±3% (kg)		1.7		2.4	4.3	7.1	14.9	24.5	46	61.8	

ST-RM series

RATIO : 10.15.20.25.30.40.50 (雙段 2-Stage)



搭配行星減速機 - 雙邊免鍵軸套

Fitted with Planetary Reducer - Double Clamping

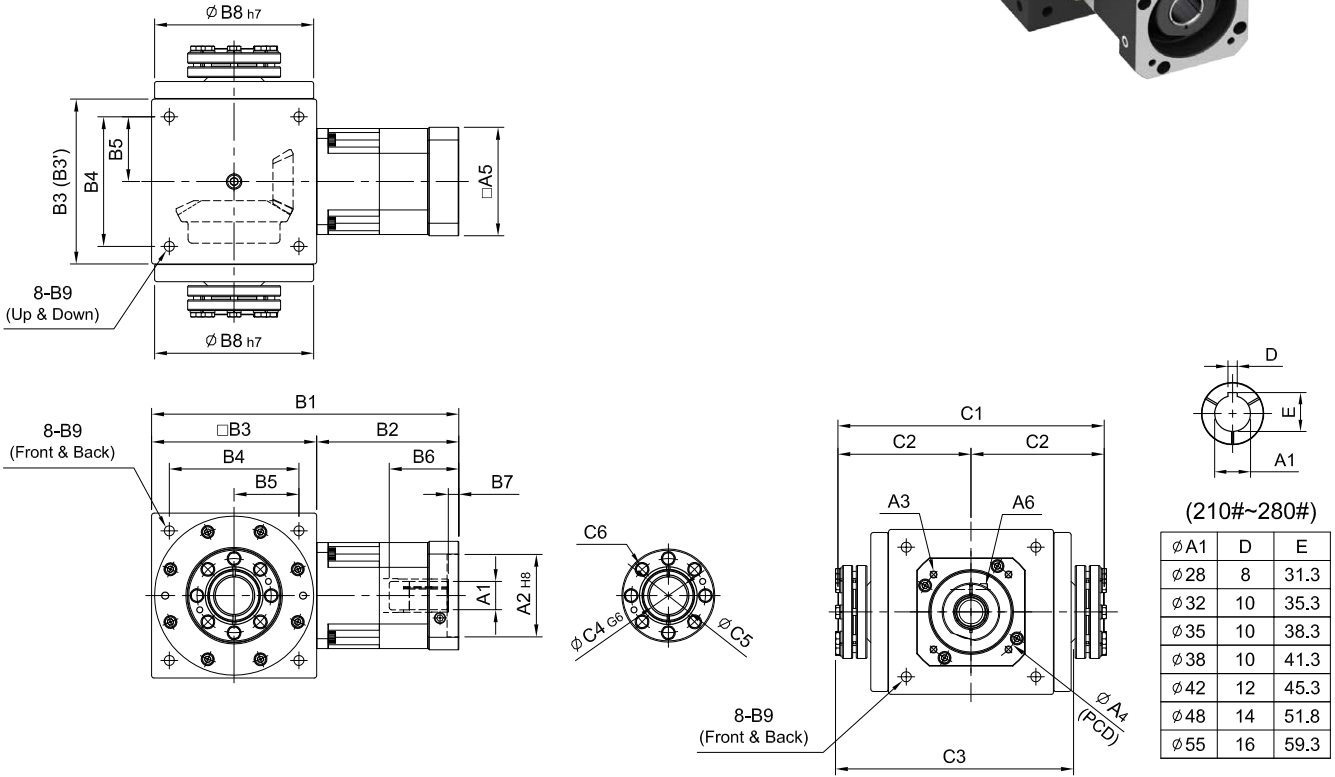

unit: mm

Model Code	65	75	90	110	140	170	210	240	280		
A	A1	8·9·11	8·9·11	11·14·16·19	11·14·16·19	(14)·16·19	16·19·22·24	22·24·28·32·35	28·32·35·38	35·38·42·48·55	38·42·48·55
	A2	30·40·50	30·40·50	50·60·70	50·60·70	50·70·80·95	70·80·95·110	95·110·130	110·130·180	114.3·180·230·250	114.3·180·230·250
	A3	M3·M4·M5	M3·M4·M5	M4·M5·M6	M4·M5·M6	M5·M6	M5·M6·M8	M6·M8·M10	M8·M10·M12	M10·M12·M16	M12·M16
	A4	46·60·63	46·60·63	70·75·90	70·75·90	70·90·100·115	90·100·115·145	115·145·165	145·165·200	200·215·265·300	200·215·265·300
	A5	46·55	46·55	64·70·80	64·70·80	80·92·110	92·110·130	122·130·150	146·150·190	182·200·250·265	222·220·250·265
	A6	M4 x P0.7	M4 x P0.7	M5 x P0.8	M5 x P0.8	M5 x P0.8	M6 x P1.0	M8 x P1.25	M10 x P1.5	M10 x P1.5	M10 x P1.5
B	B1	132	137	149·157	165·173	(191)·203	260	313·334	399	479.5	580.5
	B2	67	62	74·82	75·83	(81)·93	120	143·164	189	239.5	300.5
	B3(B3')	65	75(74)	75(74)	90	110	140	170(168)	210	240	280
	B4	52	60	60	72	88	110	134	170	190	220
	B5	26	30	30	36	44	55	67	85	95	110
	B6	26	26	33.5·41.5	33.5·41.5	(33.5)·45.5	59	67·83	85	116.5	117.5
	B7	5	5	5	6	(6)·10	9	10·11	10	13.5	12.5
	B8	62	73	73	88	106	135	164	205	228	275
B9	M5 x P0.8	M6 x P1.0	M6 x P1.0	M6 x P1.0	M8 x P1.25	M10 x P1.5	M12 x P1.75	M16 x P2.0	M16 x P2.0	M16 x P2.0	
C	C1	124	140	140	158	194	230	276	320	356	412
	C2	62	70	70	79	97	115	138	160	178	206
	C3	136	150	150	166	198	232	280	327	370	411.7
	C4	14	14	14	18	22	32	40	50	55	60
	C5	22	22	22	28	34	44	52	65	73	83
	C6	6-M6	6-M6	6-M6	6-M6	8-M6	8-M6	8-M8	8-M8	8-M8	8-M8
Weight ±3% (kg)	1.9	3.6	3.4	4.8	8.5	14.2	24	52	78.6		

ST-DM series

RATIO : 1.2.3.4.5 (單段 1-Stage)



單入力軸心 - 雙邊免鍵軸套

Single Input Shaft - Double Clamping

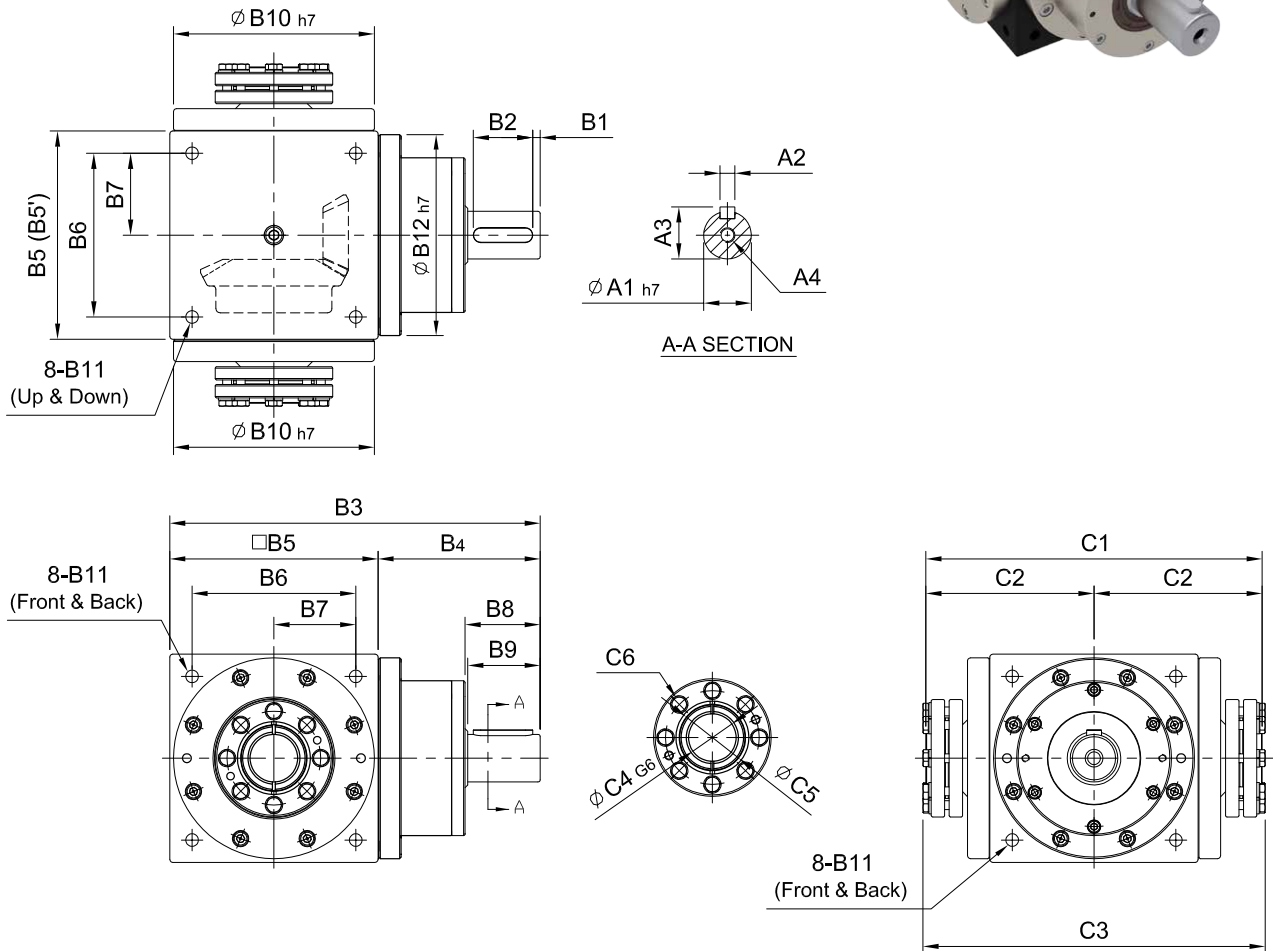

unit: mm

Model Code	65	65 (1:1)	75	90	110	140	170	210	240	280	
	A	A1	14	16	18	22	32	40	50	55	60
	A2	5	5	6	6	10	12	14	16	18	
	A3	16	18	20.5	24.5	35	43	53.5	59	64	
	A4	M5 x P0.8	M5 x P0.8	M8 x P1.25	M8 x P1.25	M10 x P1.5	M12 x P1.75	M12 x P1.75	M16 x P2.0	M16 x P2.0	
B	B1	2.5	2.5	5	5	5	5	5	5	5	
	B2	15	25	25	30	40	50	65	70	90	
	B3	127.5	143	168.5	207	250	300	375	430	505	
	B4	62.5	68	78.5	97	110	130	165	190	225	
	B5(B5')	65	75(74)	90	110	140	170(168)	210	240	280	
	B6	52	60	72	88	110	134	170	190	220	
	B7	26	30	36	44	55	67	85	95	110	
	B8	22	32	38	43	53.5	64	77	82	105	
	B9	20	30	35	40	50	60	75	80	100	
	B10	62	64	73	88	106	135	164	205	228	275
	B11	M5 x P0.8	M6 x P1.0	M6 x P1.0	M8 x P1.25	M10 x P1.5	M12 x P1.75	M16 x P2.0	M16 x P2.0	M16 x P2.0	
	B12	-	73	88	106	135	164	205	228	219	
C	C1	124	129	140	158	194	230	276	320	356	412
	C2	62	64.5	70	79	97	115	138	160	178	206
	C3	136	138	150	166	198	232	280	327	370	411.7
	C4	14	14	18	22	32	40	50	55	60	
	C5	22	22	28	34	44	52	65	73	83	
	C6	6-M6	6-M6	6-M6	8-M6	8-M6	8-M8	8-M8	8-M8	8-M8	8-M10
Weight $\pm 3\%$ (kg)		2.1	2.8	4.9	8.59	15.5	25	53	74.4		

ST-YM series

RATIO : 1.2.3.4.5 (單段 1-Stage)



雙入力軸心 - 雙邊免鍵軸套

Double Input Shaft - Double Clamping

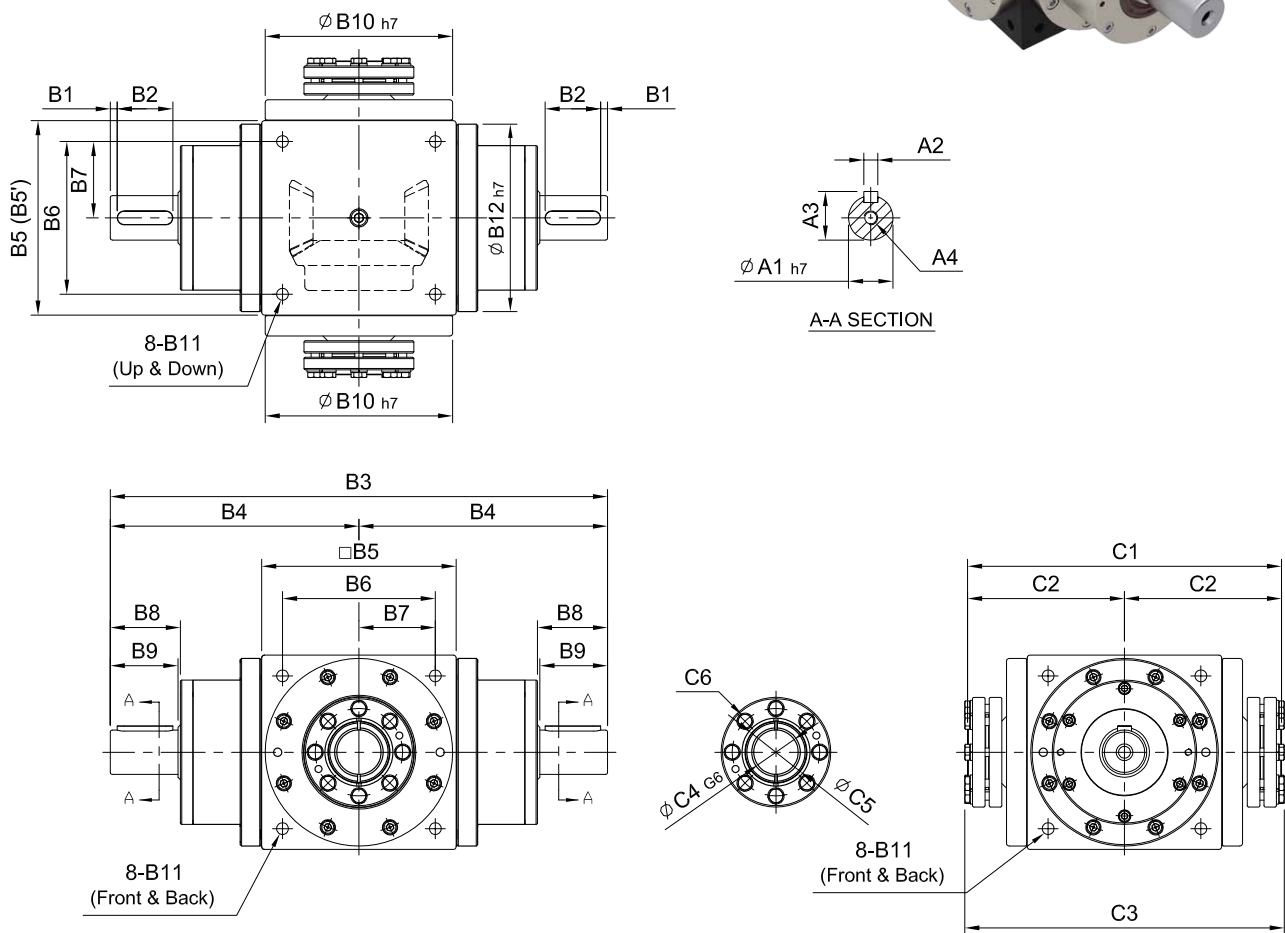

unit: mm

Model Code	65	65 (1:1)	75	90	110	140	170	210	240	280	
	A	A1	14	16	18	22	32	40	50	55	60
	A2	5	5	6	6	10	12	14	16	18	
	A3	16	18	20.5	24.5	35	43	53.5	59	64	
	A4	M5 x P0.8	M5 x P0.8	M8 x P1.25	M8 x P1.25	M10 x P1.5	M12 x P1.75	M12 x P1.75	M16 x P2.0	M16 x P2.0	
B	B1	2.5	2.5	5	5	5	5	5	5	5	
	B2	15	25	25	30	40	50	65	70	90	
	B3	190	210	247	304	360	430	540	620	730	
	B4	95	95	123.5	152	180	215	270	310	365	
	B5(B5')	65	75(74)	90	110	140	170(168)	210	240	280	
	B6	52	60	72	88	110	134	170	190	220	
	B7	26	30	36	44	55	67	85	95	110	
	B8	22	32	38	43	53.5	64	77	82	105	
	B9	20	30	35	40	50	60	75	80	100	
	B10	62	64	73	88	106	135	164	205	228	275
	B11	M5 x P0.8	M6 x P1.0	M6 x P1.0	M8 x P1.25	M10 x P1.5	M12 x P1.75	M16 x P2.0	M16 x P2.0	M16 x P2.0	M16 x P2.0
	B12	-	73	88	106	135	164	205	228	219	
C	C1	124	129	140	158	194	230	276	320	356	412
	C2	62	64.5	70	79	97	115	138	160	178	206
	C3	136	138	150	166	198	232	280	327	370	411.7
	C4	14	14	18	22	32	40	50	55	60	
	C5	22	22	28	34	44	52	65	73	83	
	C6	6-M6	6-M6	6-M6	8-M6	8-M6	8-M8	8-M8	8-M8	8-M8	8-M10
Weight $\pm 3\%$ (kg)		2.85	3.6	6.2	11.5	18	28	57	96		

ST-FS series

RATIO : 1.2.3.4.5 (單段 1-Stage)

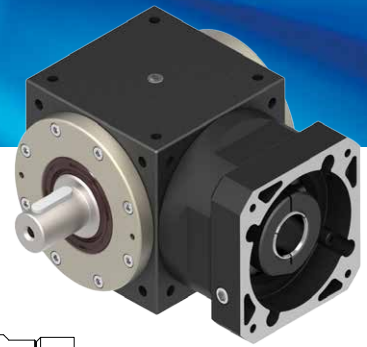

入力法蘭 - 單出力軸心

Input Flange - Single Output Shaft

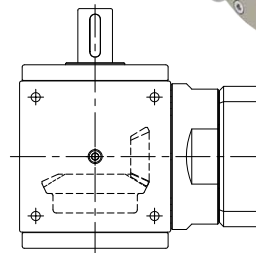
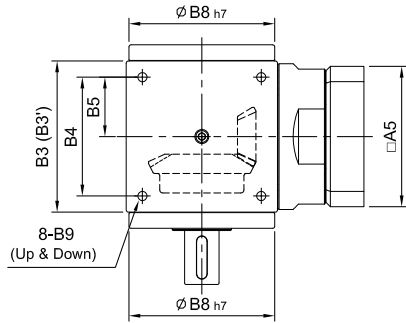

R 軸
Shaft Direction

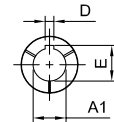
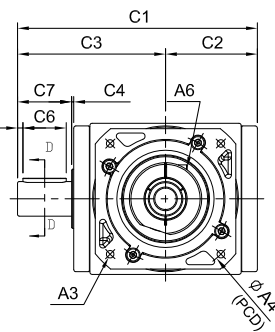
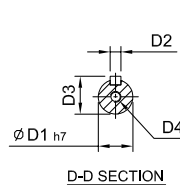
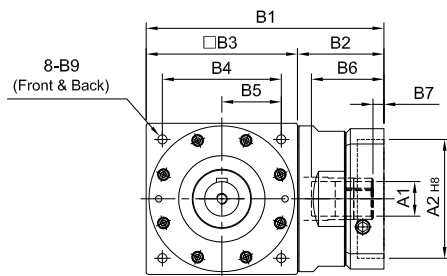

(170#~280#)

ØA1	D	E
Ø35	10	38.3
Ø38	10	41.3
Ø42	12	45.3
Ø48	14	51.8
Ø55	16	59.3
Ø60	18	64.4
Ø65	18	69.4

unit: mm

Model Code	65	65 (1:1)	75	90	110	140	170	210	240	280
A	A1	9 · 11 · 14	14 · 19	16 · 19 · 22 · 24	19 · 22 · 24	24 · 28 · 32 · 35	35 · 38	35 · 38 · 42 · 48 · 55	48 · 55 · 60	55 · 60 · 65
	A2	50 · 60 · 70	50 · 60 · 70	70 · 80 · 95 · 110	70 · 80 · 95 · 110	95 · 110 · 130	110 · 130 · 180	114.3 · 180 · 230	114.3 · 230 · 250	114.3 · 180 · 230 · 250
	A3	M4 · M5 · M6	M4 · M5 · M6	M5 · M6 · M8	M5 · M6 · M8	M6 · M8 · M10	M8 · M10 · M12	M10 · M12 · M16	M12 · M16	M12 · M16
	A4	70 · 75 · 90	70 · 75 · 90	90 · 100 · 115 · 145	90 · 100 · 115 · 145	115 · 145 · 165	145 · 165 · 200	200 · 215 · 265	200 · 265 · 300	200 · 215 · 265 · 300
	A5	64 · 70 · 80	64 · 70 · 80	92 · 110 · 130	92 · 110 · 130	122 · 130 · 150	146 · 150 · 190	182 · 200 · 250	222 · 250 · 265	222 · 220 · 250 · 265
	A6	M5 x P0.8	M5 x P0.8	M6 x P1.0	M6 x P1.0	M8 x P1.25	M10 x P1.5	M10 x P1.5	M10 x P1.5	M10 x P1.5
B	B1	110	115 · 124	148 · 162	177 · 191	224 · 238	274	357 · 359	394.5 · 421.5 · 424.5	453.5 · 483
	B2	45	40 · 49	58 · 72	67 · 81	84 · 98	104	147	154.5 · 181.5 · 184.5	173.5 · 203
	B3(B3')	65	75(74)	90	110	140	170(168)	210	240	280
	B4	52	60	72	88	110	134	170	190	220
	B5	26	30	36	44	55	67	85	95	110
	B6	36	36 · 42	51 · 65.5	51 · 65.5	68 · 81	84.5	117	115 · 142 · 145	112.5 · 142
	B7	7	7	9 · 23.5	9 · 23.5	9 · 10	9.5	14 · 16	12.5 · 15.5	12.5 · 42
	B8	62 64	73	88	106	135	164	205	228	275
B9	M5 x P0.8	M6 x P1.0	M6 x P1.0	M8 x P1.25	M10 x P1.5	M12 x P1.75	M16 x P2.0	M16 x P2.0	M16 x P2.0	M16 x P2.0
C	C1	102 107	128	151	182	222	262	323	370	425
	C2	40	42.5	48	57	70	85	100	123	161
	C3	62 64.5	80	94	112	137	162	200	226	264
	C4	2	2	2	2	2	2	2	2	3
	C5	2.5	2.5	5	5	5	5	5	5	5
	C6	15	25	25	30	40	50	65	70	90
	C7	20	30	35	40	50	60	75	80	100
D	D1	14	16	18	22	32	40	50	55	60
	D2	5	5	6	6	10	12	14	16	18
	D3	16	18	20.5	24.5	35	43	53.5	59	64
	D4	M5 x P0.8	M5 x P0.8	M5 x P0.8	M8 x P1.25	M10 x P1.5	M12 x P1.75	M12 x P1.75	M16 x P2.0	M16 x P2.0
Weight ±3% (kg)	1.7	2.4	4.3	7.1	14.9	24.5	46	68.5		

ST-RS series

RATIO : 10.15.20.25.30.40.50 (雙段 2-Stage)



搭配行星減速機 - 單出力軸心

Fitted with Planetary Reducer - Single Output Shaft

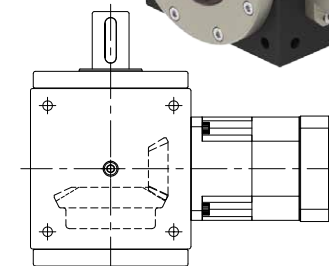
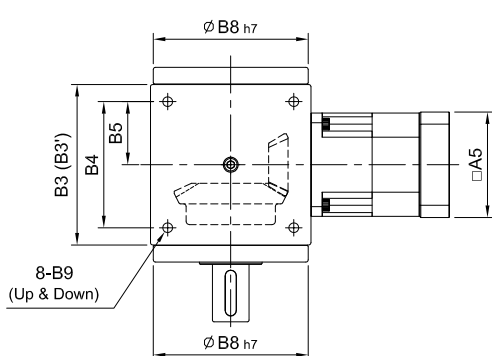

R 軸
Shaft Direction

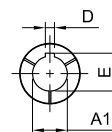
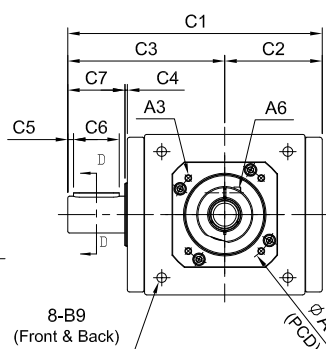
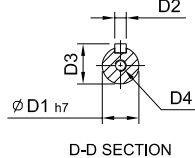
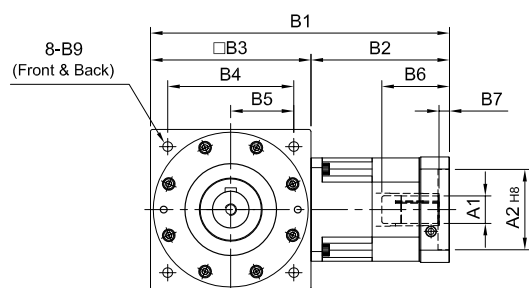

(210#~280#)

ØA1	D	E
Ø28	8	31.3
Ø32	10	35.3
Ø35	10	38.3
Ø38	10	41.3
Ø42	12	45.3
Ø48	14	51.8
Ø55	16	59.3

unit: mm

Model Code	unit: mm										
	65	75	90	110	140	170	210	240	280		
A	A1	8 · 9 · 11	8 · 9 · 11	11 · 14 · 16 · 19	11 · 14 · 16 · 19	(14) · 16 · 19	16 · 19 · 22 · 24	22 · 24 · 28 · 32 · 35	28 · 32 · 35 · 38	35 · 38 · 42 · 48 · 55	38 · 42 · 48 · 55
	A2	30 · 40 · 50	30 · 40 · 50	50 · 60 · 70	50 · 60 · 70	50 · 70 · 80 · 95	70 · 80 · 95 · 110	95 · 110 · 130	110 · 130 · 180	114.3 · 180 · 230 · 250	114.3 · 180 · 230 · 250
	A3	M3 · M4 · M5	M3 · M4 · M5	M4 · M5 · M6	M4 · M5 · M6	M5 · M6	M5 · M6 · M8	M6 · M8 · M10	M8 · M10 · M12	M10 · M12 · M16	M12 · M16
	A4	46 · 60 · 63	46 · 60 · 63	70 · 75 · 90	70 · 75 · 90	70 · 90 · 100 · 115	90 · 100 · 115 · 145	115 · 145 · 165	145 · 165 · 200	200 · 215 · 265 · 300	200 · 215 · 265 · 300
	A5	46 · 55	46 · 55	64 · 70 · 80	64 · 70 · 80	80 · 92 · 110	92 · 110 · 130	122 · 130 · 150	146 · 150 · 190	182 · 200 · 250 · 265	222 · 220 · 250 · 265
	A6	M4 x P0.7	M4 x P0.7	M5 x P0.8	M5 x P0.8	M5 x P0.8	M6 x P1.0	M8 x P1.25	M10 x P1.5	M10 x P1.5	M10 x P1.5
B	B1	132	137	149 · 157	165 · 173	(191) · 203	260	313 · 334	399	479.5	580.5
	B2	67	62	74 · 82	75 · 83	(81) · 93	120	143 · 164	189	239.5	300.5
	B3(B3')	65	75(74)	75(74)	90	110	140	170(168)	210	240	280
	B4	52	60	60	72	88	110	134	170	190	220
	B5	26	30	30	36	44	55	67	85	95	110
	B6	26	26	33.5 · 41.5	33.5 · 41.5	(33.5) · 45.5	59	67 · 83	85	116.5	117.5
B7	5	5	5	6	(6) · 10	9	10 · 11	10	13.5	12.5	
B8	62	73	73	88	106	135	164	205	228	275	
B9	M5 x P0.8	M6 x P1.0	M6 x P1.0	M6 x P1.0	M8 x P1.25	M10 x P1.5	M12 x P1.75	M16 x P2.0	M16 x P2.0	M16 x P2.0	
C	C1	102	128	128	151	182	222	262	323	370	425
	C2	40	48	48	57	70	85	100	123	144	161
	C3	62	80	80	94	112	137	162	200	226	264
	C4	2	2	2	2	2	2	2	2	2	3
	C5	2.5	2.5	2.5	5	5	5	5	5	5	5
C6	15	25	25	25	30	40	50	65	70	90	
C7	20	30	30	35	40	50	60	75	80	100	
D	D1	14	16	16	18	22	32	40	50	55	60
	D2	5	5	5	6	6	10	12	14	16	18
	D3	16	18	18	20.5	24.5	35	43	53.5	59	64
	D4	M5 x P0.8	M5 x P0.8	M5 x P0.8	M5 x P0.8	M8 x P1.25	M10 x P1.5	M12 x P1.75	M12 x P1.75	M16 x P2.0	M16 x P2.0
Weight ±3% (kg)	1.9	3.6	3.4	4.8	8.5	14.2	24	52	79.8		

ST-DS series

RATIO : 1.2.3.4.5 (單段 1-Stage)



單入力軸心 - 單出力軸心

Single Input Shaft - Single Output Shaft

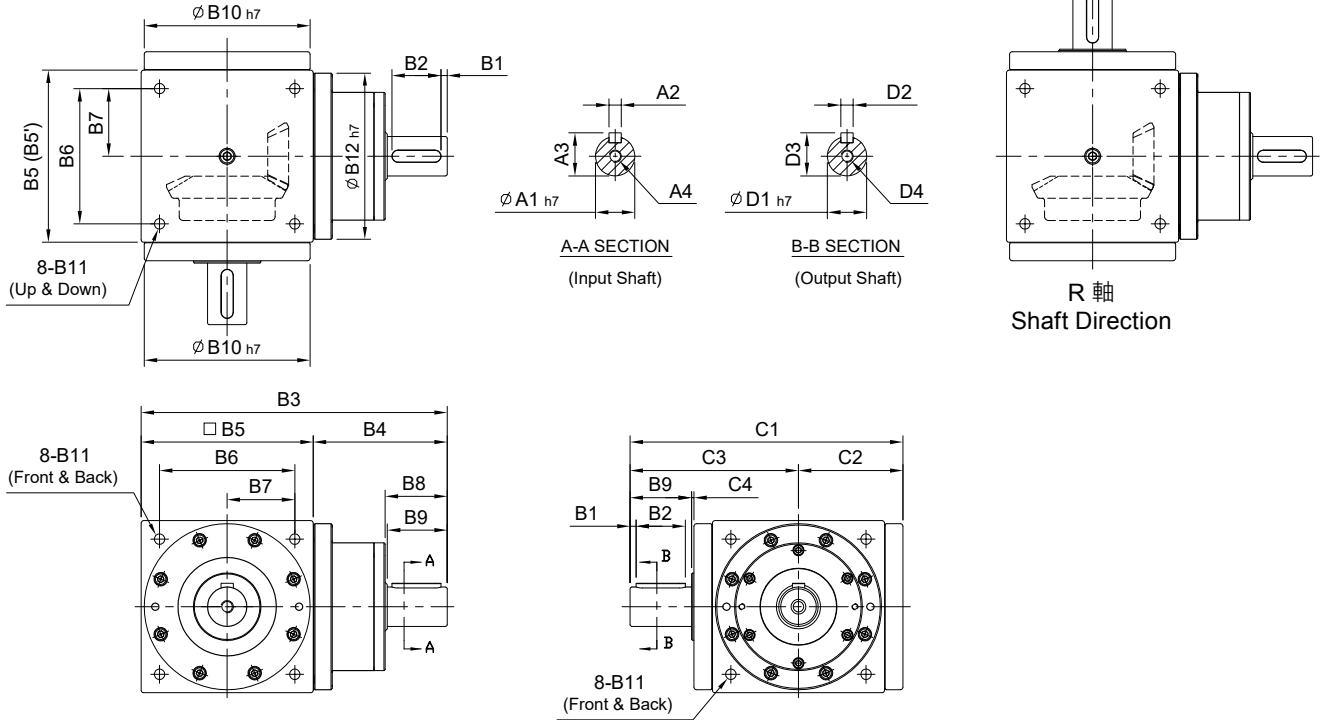

unit: mm

Model Code	65		75	90	110	140	170	210	240	280	
	65	65 (1:1)									
A	A1	14	16	18	22	32	40	50	55	60	
	A2	5	5	6	6	10	12	14	16	18	
	A3	16	18	20.5	24.5	35	43	53.5	59	64	
	A4	M5 x P0.8	M5 x P0.8	M8 x P1.25	M8 x P1.25	M10 x P1.5	M12 x P1.75	M12 x P1.75	M16 x P2.0	M16 x P2.0	
B	B1	2.5	2.5	5	5	5	5	5	5	5	
	B2	15	25	25	30	40	50	65	70	90	
	B3	127.5	143	168.5	207	250	300	375	430	505	
	B4	62.5	68	78.5	97	110	130	165	190	225	
	B5(B5')	65	75(74)	90	110	140	170(168)	210	240	280	
	B6	52	60	72	88	110	134	170	190	220	
	B7	26	30	36	44	55	67	85	95	110	
	B8	22	32	38	43	53.5	64	77	82	105	
	B9	20	30	35	40	50	60	75	80	100	
	B10	62	64	73	88	106	135	164	205	228	275
	B11	M5 x P0.8	M6 x P1.0	M6 x P1.0	M8 x P1.25	M10 x P1.5	M12 x P1.75	M16 x P2.0	M16 x P2.0	M16 x P2.0	M16 x P2.0
	B12	-	73	88	106	135	164	205	228	219	
C	C1	102	107	128	151	182	222	262	323	370	425
	C2	40	42.5	48	57	70	85	100	123	144	161
	C3	62	64.5	80	94	112	137	162	200	226	264
	C4	2	2	2	2	2	2	2	2	2	3
D	D1	14	16	18	22	32	40	50	55	60	
	D2	5	5	6	6	10	12	14	16	18	
	D3	16	18	20.5	24.5	35	43	53.5	59	64	
	D4	M5 x P0.8	M5 x P0.8	M5 x P0.8	M8 x P1.25	M10 x P1.5	M12 x P1.75	M12 x P1.75	M16 x P2.0	M16 x P2.0	
Weight ±3% (kg)		2.1	2.8	4.9	8.59	15.5	25	53	79.5		

ST-YS series

RATIO : 1.2.3.4.5 (單段 1-Stage)

雙入力軸心 - 單出力軸心

Double Input Shaft - Single Output Shaft



ST

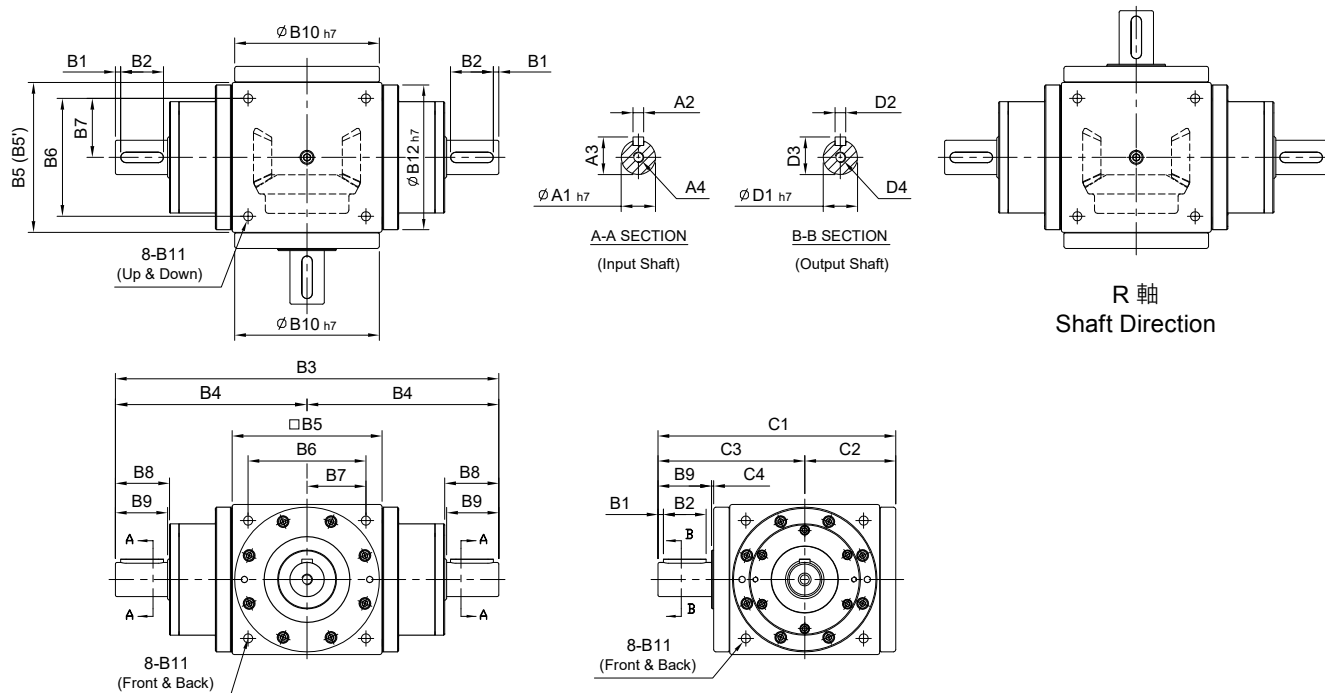

unit: mm

	Model Code	65	65 (1:1)	75	90	110	140	170	210	240	280
		A	A1	14	16	18	22	32	40	50	55
	A2	5	5	6	6	10	12	14	16	18	
	A3	16	18	20.5	24.5	35	43	53.5	59	64	
	A4	M5 x P0.8	M5 x P0.8	M8 x P1.25	M8 x P1.25	M10 x P1.5	M12 x P1.75	M12 x P1.75	M16 x P2.0	M16 x P2.0	
B	B1	2.5	2.5	5	5	5	5	5	5	5	
	B2	15	25	25	30	40	50	65	70	90	
	B3	190	210	247	304	360	430	540	620	730	
	B4	95	105	123.5	152	180	215	270	310	365	
	B5(B5')	65	75(74)	90	110	140	170(168)	210	240	280	
	B6	52	60	72	88	110	134	170	190	220	
	B7	26	30	36	44	55	67	85	95	110	
	B8	22	32	38	43	53.5	64	77	82	105	
	B9	20	30	35	40	50	60	75	80	100	
	B10	62	64	73	88	106	135	164	205	228	275
	B11	M5 x P0.8	M6 x P1.0	M6 x P1.0	M8 x P1.25	M10 x P1.5	M12 x P1.75	M16 x P2.0	M16 x P2.0	M16 x P2.0	M16 x P2.0
	B12	-	73	88	106	135	164	205	228	219	
C	C1	102	107	128	151	182	222	262	323	370	425
	C2	40	42.5	48	57	70	85	100	123	144	161
	C3	62	64.5	80	94	112	137	162	200	226	264
	C4	2	2	2	2	2	2	2	2	2	3
D	D1	14	16	18	22	32	40	50	55	60	
	D2	5	5	6	6	10	12	14	16	18	
	D3	16	18	20.5	24.5	35	43	53.5	59	64	
	D4	M5 x P0.8	M5 x P0.8	M5 x P0.8	M8 x P1.25	M10 x P1.5	M12 x P1.75	M12 x P1.75	M16 x P2.0	M16 x P2.0	M16 x P2.0
Weight ±3% (kg)		2.85	3.6	6.2	11.5	18	28	57	101.1		

ST-FV series

RATIO : 1.2.3.4.5 (單段 1-Stage)

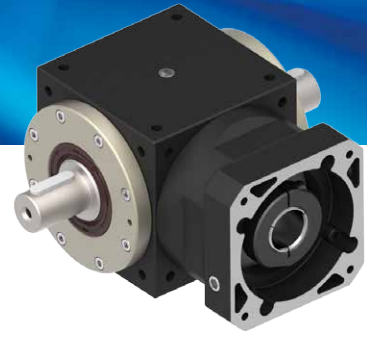

入力法蘭 - 雙出力軸心

Input Flange - Double Output Shaft

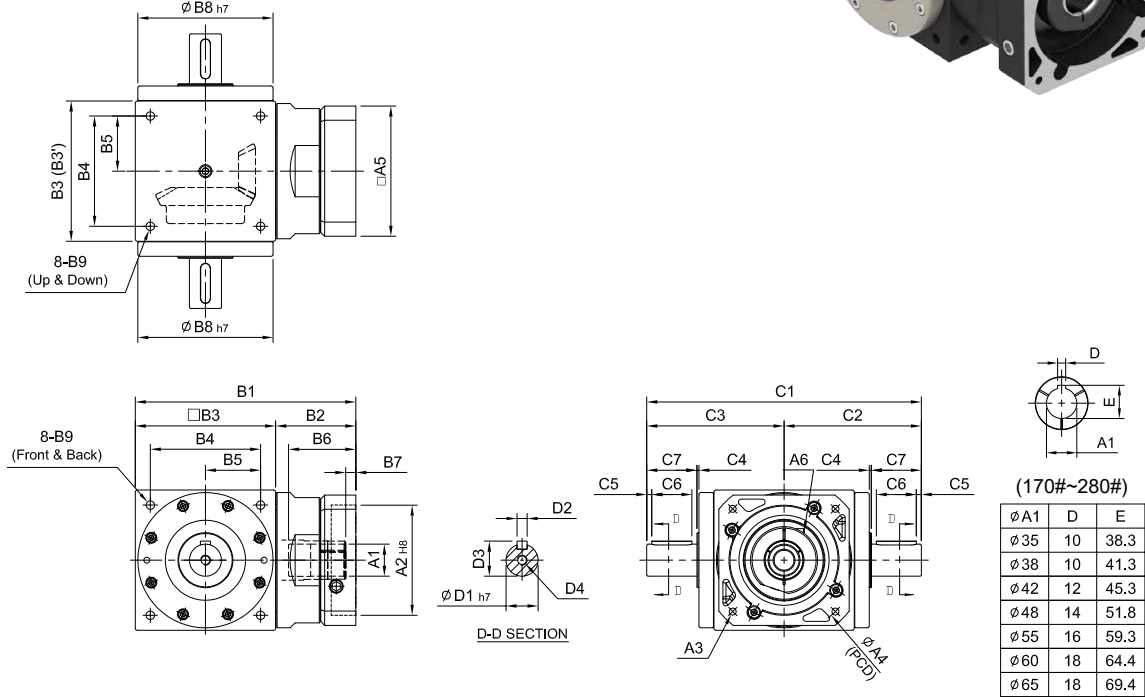

unit: mm

	Model Code	65	65 (1:1)	75	90	110	140	170	210	240	280
		A	A1	9 · 11 · 14	14 · 19	16 · 19 · 22 · 24	19 · 22 · 24	24 · 28 · 32 · 35	35 · 38	35 · 38 · 42 · 48 · 55	48 · 55 · 60
	A2	50 · 60 · 70	50 · 60 · 70	70 · 80 · 95 · 110	70 · 80 · 95 · 110	95 · 110 · 130	110 · 130 · 180	114.3 · 180 · 230	114.3 · 230 · 250	114.3 · 180 · 230 · 250	
	A3	M4 · M5 · M6	M4 · M5 · M6	M5 · M6 · M8	M5 · M6 · M8	M6 · M8 · M10	M8 · M10 · M120	M10 · M12 · M16	M12 · M16	M12 · M16	
	A4	70 · 75 · 90	70 · 75 · 90	90 · 100 · 115 · 145	90 · 100 · 115 · 145	115 · 145 · 165	145 · 165 · 200	200 · 215 · 265	200 · 265 · 300	200 · 215 · 265 · 300	
	A5	64 · 70 · 80	64 · 70 · 80	92 · 110 · 130	92 · 110 · 130	122 · 130 · 150	146 · 150 · 190	182 · 200 · 250	222 · 250 · 265	222 · 220 · 250 · 265	
	A6	M5 x P0.8	M5 x P0.8	M6 x P1.0	M6 x P1.0	M8 x P1.25	M10 x P1.5	M10 x P1.5	M10 x P1.5	M10 x P1.5	
B	B1	110	115 · 124	148 · 162	177 · 191	224 · 238	274	357 · 359	394.5 · 421.5 · 424.5	453.5 · 483	
	B2	45	40 · 49	58 · 72	67 · 81	84 · 98	104	147	154.5 · 181.5 · 184.5	173.5 · 203	
	B3(B3')	65	75(74)	90	110	140	170(168)	210	240	280	
	B4	52	60	72	88	110	134	170	190	220	
	B5	26	30	36	44	55	67	85	95	110	
	B6	36	36 · 42	51 · 65.5	51 · 65.5	68 · 81	84.5	117	115 · 142 · 145	112.5 · 142	
	B7	7	7	9 · 23.5	9 · 23.5	9 · 10	9.5	14 · 16	12.5 · 15.5	12.5 · 42	
	B8	62 64	73	88	106	135	164	205	228	275	
	B9	M5 x P0.8	M6 x P1.0	M6 x P1.0	M8 x P1.25	M10 x P1.5	M12 x P1.75	M16 x P2.0	M16 x P2.0	M16 x P2.0	
C	C1	124 129	160	188	224	274	324	400	452	528	
	C2	62 64.5	80	94	112	137	162	200	226	264	
	C3	62 64.5	80	94	112	137	162	200	226	264	
	C4	2	2	2	2	2	2	2	2	3	
	C5	2.5	2.5	5	5	5	5	5	5	5	
	C6	15	25	25	30	40	50	65	70	90	
	C7	20	30	35	40	50	60	75	80	100	
D	D1	14	16	18	22	32	40	50	55	60	
	D2	5	5	6	6	10	12	14	16	18	
	D3	16	18	20.5	24.5	35	43	53.5	59	64	
	D4	M5 x P0.8	M5 x P0.8	M5 x P0.8	M8 x P1.25	M10 x P1.5	M12 x P1.75	M12 x P1.75	M16 x P2.0	M16 x P2.0	
Weight ±3% (kg)		1.7	2.4	4.3	7.1	14.9	24.5	46	70.8		

ST-RV series

RATIO : 10.15.20.25.30.40.50 (雙段 2-Stage)

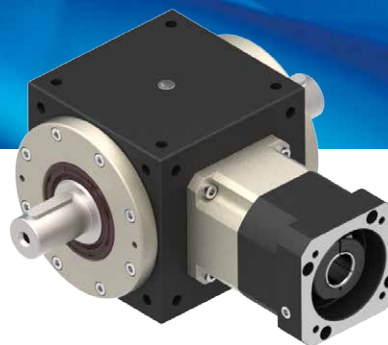

搭配行星減速機 - 雙出力軸心

Fitted with Planetary Reducer - Double Output Shaft

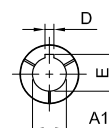
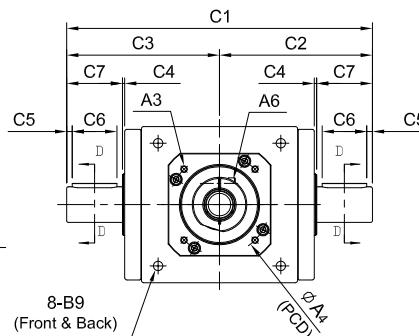
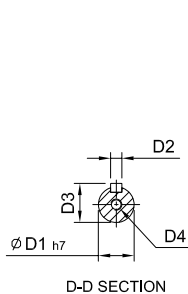
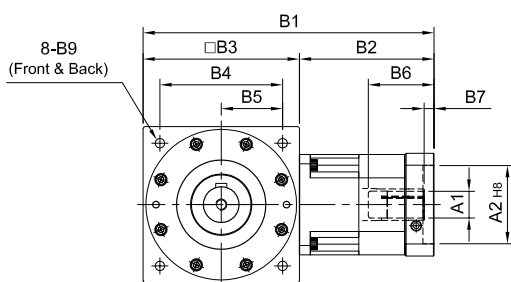
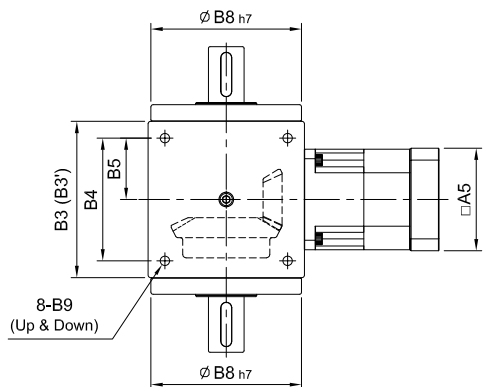

(210#~280#)

Ø A1	D	E
Ø 28	8	31.3
Ø 32	10	35.3
Ø 35	10	38.3
Ø 38	10	41.3
Ø 42	12	45.3
Ø 48	14	51.8
Ø 55	16	59.3

unit: mm

Model Code	65	75	90	110	140	170	210	240	280		
A	A1	8 · 9 · 11	8 · 9 · 11	11 · 14 · 16 · 19	11 · 14 · 16 · 19	(14) · 16 · 19	16 · 19 · 22 · 24	22 · 24 · 28 · 32 · 35	28 · 32 · 35 · 38	35 · 38 · 42 · 48 · 55	
	A2	30 · 40 · 50	30 · 40 · 50	50 · 60 · 70	50 · 60 · 70	50 · 70 · 80 · 95	70 · 80 · 95 · 110	95 · 110 · 130	110 · 130 · 180	114.3 · 180 · 230 · 250	
	A3	M3 · M4 · M5	M3 · M4 · M5	M4 · M5 · M6	M4 · M5 · M6	M5 · M6	M5 · M6 · M8	M6 · M8 · M10	M8 · M10 · M12	M10 · M12 · M16	M12 · M16
	A4	46 · 60 · 63	46 · 60 · 63	70 · 75 · 90	70 · 75 · 90	70 · 90 · 100 · 115	90 · 100 · 115 · 145	115 · 145 · 165	145 · 165 · 200	200 · 215 · 265 · 300	200 · 215 · 265 · 300
	A5	46 · 55	46 · 55	64 · 70 · 80	64 · 70 · 80	80 · 92 · 110	92 · 110 · 130	122 · 130 · 150	146 · 150 · 190	182 · 200 · 250 · 265	222 · 220 · 250 · 265
	A6	M4 x P0.7	M4 x P0.7	M5 x P0.8	M5 x P0.8	M5 x P0.8	M6 x P1.0	M8 x P1.25	M10 x P1.5	M10 x P1.5	M10 x P1.5
B	B1	132	137	149 · 157	165 · 173	(191) · 203	260	313 · 334	399	479.5	580.5
	B2	67	62	74 · 82	75 · 83	(81) · 93	120	143 · 164	189	239.5	300.5
	B3(B3')	65	75(74)	75(74)	90	110	140	170(168)	210	240	280
	B4	52	60	60	72	88	110	134	170	190	220
	B5	26	30	30	36	44	55	67	85	95	110
	B6	26	26	33.5 · 41.5	33.5 · 41.5	(33.5) · 45.5	59	67 · 83	85	116.5	117.5
	B7	5	5	5	6	(6) · 10	9	10 · 11	10	13.5	12.5
	B8	62	73	73	88	106	135	164	205	228	275
B9	M5 x P0.8	M6 x P1.0	M6 x P1.0	M6 x P1.0	M8 x P1.25	M10 x P1.5	M12 x P1.75	M16 x P2.0	M16 x P2.0	M16 x P2.0	
C	C1	124	160	160	188	224	274	324	400	452	528
	C2	62	80	80	94	112	137	162	200	226	264
	C3	62	80	80	94	112	137	162	200	226	264
	C4	2	2	2	2	2	2	2	2	2	3
	C5	2.5	2.5	2.5	5	5	5	5	5	5	5
	C6	15	25	25	25	30	40	50	65	70	90
	C7	20	30	30	35	40	50	60	75	80	100
D	D1	14	16	16	18	22	32	40	50	55	60
	D2	5	5	5	6	6	10	12	14	16	18
	D3	16	18	18	20.5	24.5	35	43	53.5	59	64
	D4	M5 x P0.8	M5 x P0.8	M5 x P0.8	M5 x P0.8	M8 x P1.25	M10 x P1.5	M12 x P1.75	M12 x P1.75	M16 x P2.0	M16 x P2.0
Weight ±3% (kg)	1.9	3.6	3.4	4.8	8.5	14.2	24	52	82.1		

ST-DV series

RATIO : 1.2.3.4.5 (單段 1-Stage)

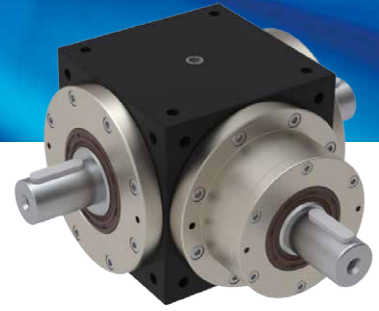

單入力軸心 - 雙出力軸心

Single Input Shaft - Double Output Shaft

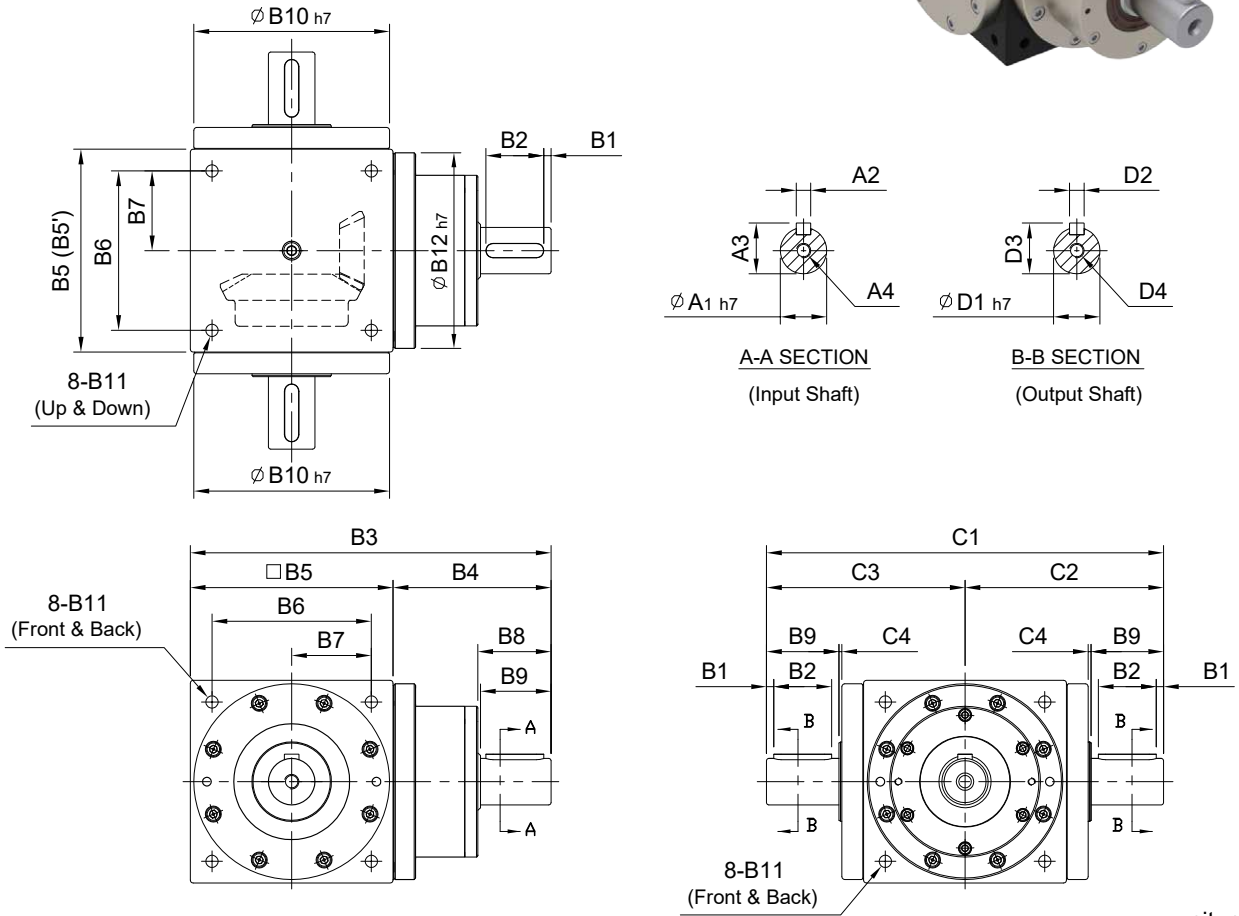

unit: mm

Model Code	65	65 (1:1)	75	90	110	140	170	210	240	280	
	A	A1	14	16	18	22	32	40	50	55	60
	A2	5	5	6	6	10	12	14	16	18	
	A3	16	18	20.5	24.5	35	43	53.5	59	64	
	A4	M5 x P0.8	M5 x P0.8	M8 x P1.25	M8 x P1.25	M10 x P1.5	M12 x P1.75	M12 x P1.75	M16 x P2.0	M16 x P2.0	
B	B1	2.5	2.5	5	5	5	5	5	5	5	
	B2	15	25	25	30	40	50	65	70	90	
	B3	127.5	143	168.5	207	250	300	375	430	505	
	B4	62.5	68	78.5	97	110	130	165	190	225	
	B5(B5')	65	75(74)	90	110	140	170(168)	210	240	280	
	B6	52	60	72	88	110	134	170	190	220	
	B7	26	30	36	44	55	67	85	95	110	
	B8	22	32	38	43	53.5	64	77	82	105	
	B9	20	30	35	40	50	60	75	80	100	
	B10	62	64	73	88	106	135	164	205	228	275
	B11	M5 x P0.8	M6 x P1.0	M6 x P1.0	M8 x P1.25	M10 x P1.5	M12 x P1.75	M16 x P2.0	M16 x P2.0	M16 x P2.0	M16 x P2.0
	B12	-	73	88	106	135	164	205	228	219	
C	C1	124	129	160	188	224	324	400	452	528	
	C2	62	64.5	80	94	112	137	200	226	264	
	C3	62	64.5	80	94	112	137	200	226	264	
	C4	2	2	2	2	2	2	2	2	3	
D	D1	14	16	18	22	32	40	50	55	60	
	D2	5	5	6	6	10	12	14	16	18	
	D3	16	18	20.5	24.5	35	43	53.5	59	64	
	D4	M5 x P0.8	M5 x P0.8	M5 x P0.8	M8 x P1.25	M10 x P1.5	M12 x P1.75	M12 x P1.75	M16 x P2.0	M16 x P2.0	M16 x P2.0
Weight ±3% (kg)		2.1	2.8	4.9	8.59	15.5	25	53	81.8		

ST-YV series

RATIO : 1.2.3.4.5 (單段 1-Stage)



雙入力軸心 - 雙出力軸心

Double Input Shaft - Double Output Shaft

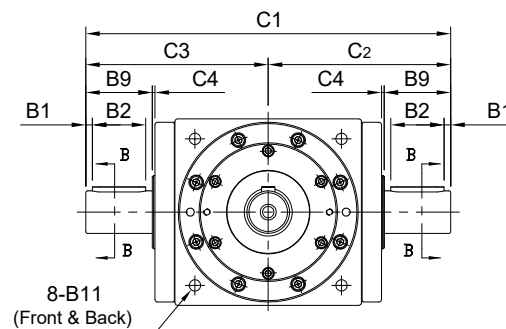
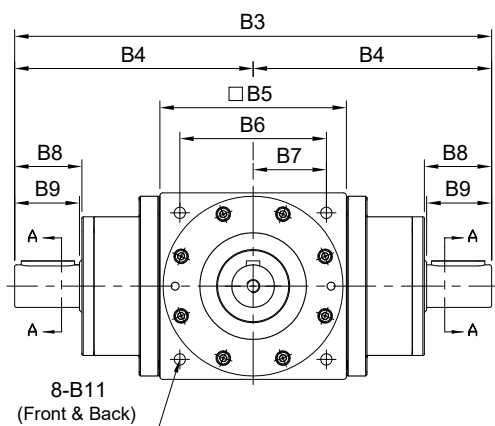
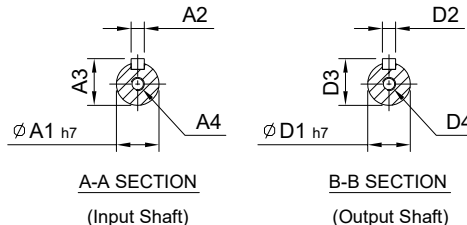
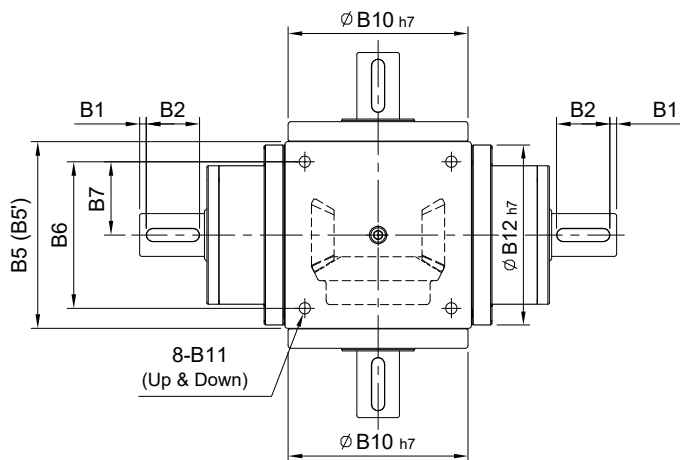

unit: mm

Model Code	Model										
	65	65 (1:1)	75	90	110	140	170	210	240	280	
A	A1	14	16	18	22	32	40	50	55	60	
	A2	5	5	6	6	10	12	14	16	18	
	A3	16	18	20.5	24.5	35	43	53.5	59	64	
	A4	M5 x P0.8	M5 x P0.8	M8 x P1.25	M8 x P1.25	M10 x P1.5	M12 x P1.75	M12 x P1.75	M16 x P2.0	M16 x P2.0	
B	B1	2.5	2.5	5	5	5	5	5	5	5	
	B2	15	25	25	30	40	50	65	70	90	
	B3	190	210	247	304	360	430	540	620	730	
	B4	95	105	123.5	152	180	215	270	310	365	
	B5(B5')	65	75(74)	90	110	140	170(168)	210	240	280	
	B6	52	60	72	88	110	134	170	190	220	
	B7	26	30	36	44	55	67	85	95	110	
	B8	22	32	38	43	53.5	64	77	82	105	
	B9	20	30	35	40	50	60	75	80	100	
	B10	62	64	73	88	106	135	164	205	228	275
	B11	M5 x P0.8	M6 x P1.0	M6 x P1.0	M8 x P1.25	M10 x P1.5	M12 x P1.75	M16 x P2.0	M16 x P2.0	M16 x P2.0	M16 x P2.0
	B12	-	73	88	106	135	164	205	228	219	
C	C1	124	129	160	188	224	274	324	400	452	528
	C2	62	64.5	80	94	112	137	162	200	226	264
	C3	62	64.5	80	94	112	137	162	200	226	264
	C4	2	2	2	2	2	2	2	2	2	3
D	D1	14	16	18	22	32	40	50	55	60	
	D2	5	5	6	6	10	12	14	16	18	
	D3	16	18	20.5	24.5	35	43	53.5	59	64	
	D4	M5 x P0.8	M5 x P0.8	M5 x P0.8	M8 x P1.25	M10 x P1.5	M12 x P1.75	M12 x P1.75	M16 x P2.0	M16 x P2.0	
Weight ±3% (kg)	2.85	3.6	6.2	11.5	18	28	57	103.4			



ST-FP series

RATIO : 2.3.4.5 (單段 1-Stage)

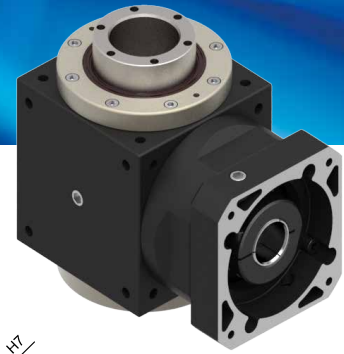

入力法蘭 - 螺桿式

Input Flange - Ball Screw

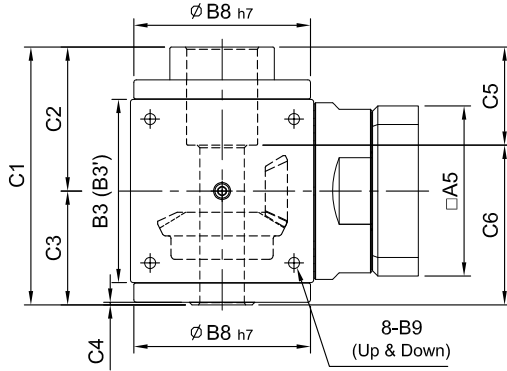

R 軸
Shaft Direction

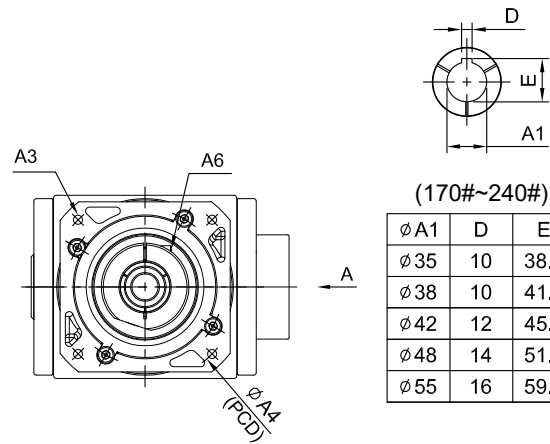
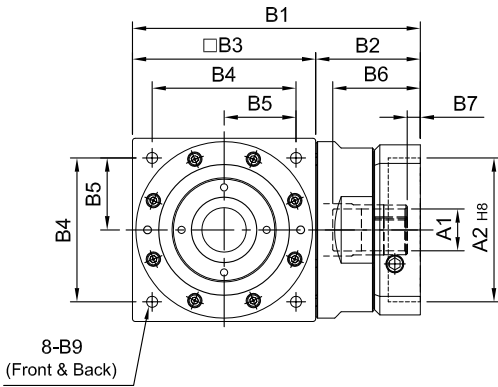
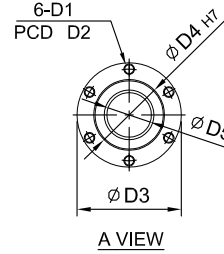

unit: mm

Model Code	75	90	110	140	170	210	240	
A	A1	14 · 19	16 · 19 · 22 · 24	19 · 22 · 24	24 · 28 · 32 · 35	35 · 38	35 · 38 · 42 · 48 · 55	48 · 55 · 60
	A2	50 · 60 · 70	70 · 80 · 95 · 110	70 · 80 · 95 · 110	95 · 110 · 130	110 · 130 · 180	114.3 · 180 · 230	114.3 · 230 · 250
	A3	M4 · M5 · M6	M5 · M6 · M8	M5 · M6 · M8	M6 · M8 · M10	M8 · M10 · M120	M10 · M12 · M16	M12 · M16
	A4	70 · 75 · 90	90 · 100 · 115 · 145	90 · 100 · 115 · 145	115 · 145 · 165	145 · 165 · 200	200 · 215 · 265	200 · 265 · 300
	A5	64 · 70 · 80	92 · 110 · 130	92 · 110 · 130	122 · 130 · 150	146 · 150 · 190	182 · 200 · 250	222 · 250 · 265
	A6	M5 x P0.8	M6 x P1.0	M6 x P1.0	M8 x P1.25	M10 x P1.5	M10 x P1.5	M10 x P1.5
B	B1	115 · 124	148 · 162	177 · 191	224 · 238	274	357 · 359	394.5 · 421.5 · 424.5
	B2	40 · 49	58 · 72	67 · 81	84 · 98	104	147	154.5 · 181.5 · 184.5
	B3(B3')	75(74)	90	110	140	170(168)	210	240
	B4	60	72	88	110	134	170	190
	B5	30	36	44	55	67	85	95
	B6	36 · 42	51 · 65.5	51 · 65.5	68 · 81	84.5	117	115 · 142 · 145
	B7	7	9 · 23.5	9 · 23.5	9 · 10	9.5	14 · 16	12.5 · 15.5
	B8	73	88	106	135	164	205	228
B9	M6 x P1.0	M6 x P1.0	M8 x P1.25	M10 x P1.5	M12 x P1.75	M16 x P2.0	M16 x P2.0	
C	C1	106	127	156	197	223	267	309
	C2	57	68	84	109	121	142	162.5
	C3	49	59	72	88	102	125	146.5
	C4	1.25	2	2	2	2.25	2.25	2.5
	C5	33	44	55	75	72	82	92
	C6	73	83	101	122	153	185	217
D	D1	M4 x P0.7	M5 x P0.8	M5 x P0.8	M8 x P1.25	M10 x P1.5	M10 x P1.5	M12 x P1.75
	D2	36	40	45	70	77	84	97
	D3	41.7	46.7	57.7	79.7	89.7	99.7	117.7
	D4	26	30	36	54	58	64	75
	D5	15	18	22	34	38	42	54
Weight ±3% (kg)		2.4	4.3	7.1	14.9	24.5	46	

ST-RP series

RATIO : 10.15.20.25.30.40.50 (雙段 2-Stage)



搭配行星減速機 - 螺桿式

Fitted with Planetary Reducer - Ball Screw

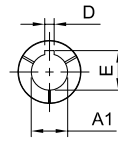
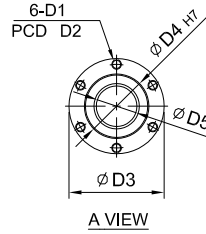
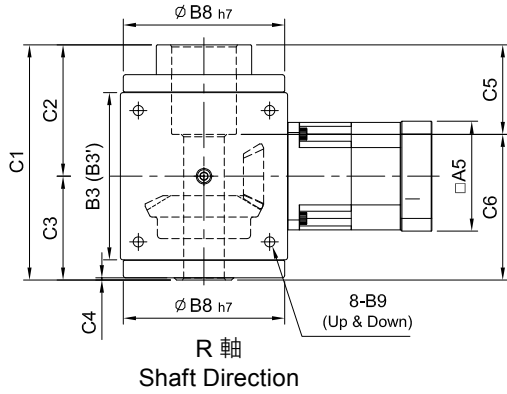

(210#~240#)

∅A1	D	E
∅28	8	31.3
∅32	10	35.3
∅35	10	38.3
∅38	10	41.3
∅42	12	45.3
∅48	14	51.8
∅55	16	59.3

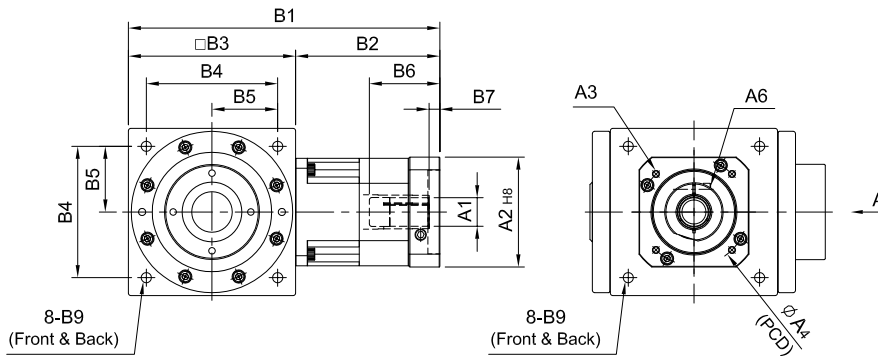

unit: mm

Model Code	Model								
	75	90	110	140	170	210	240		
A	A1	8 · 9 · 11	11 · 14 · 16 · 19	11 · 14 · 16 · 19	(14) · 16 · 19	16 · 19 · 22 · 24	22 · 24 · 28 · 32 · 35	28 · 32 · 35 · 38	35 · 38 · 42 · 48 · 55
	A2	30 · 40 · 50	50 · 60 · 70	50 · 60 · 70	50 · 70 · 80 · 95	70 · 80 · 95 · 110	95 · 110 · 130	110 · 130 · 180	114.3 · 180 · 230 · 250
	A3	M3 · M4 · M5	M4 · M5 · M6	M4 · M5 · M6	M5 · M6	M5 · M6 · M8	M6 · M8 · M10	M8 · M10 · M12	M10 · M12 · M16
	A4	46 · 60 · 63	70 · 75 · 90	70 · 75 · 90	70 · 90 · 100 · 115	90 · 100 · 115 · 145	115 · 145 · 165	145 · 165 · 200	200 · 215 · 265 · 300
	A5	46 · 55	64 · 70 · 80	64 · 70 · 80	80 · 92 · 110	92 · 110 · 130	122 · 130 · 150	146 · 150 · 190	182 · 200 · 250 · 265
	A6	M4 x P0.7	M5 x P0.8	M5 x P0.8	M5 x P0.8	M6 x P1.0	M8 x P1.25	M10 x P1.5	M10 x P1.5
B	B1	137	149 · 157	165 · 173	(191) · 203	260	313 · 334	399	479.5
	B2	62	74 · 82	75 · 83	(81) · 93	120	143 · 164	189	239.5
	B3(B3')	75(74)	75(74)	90	110	140	170(168)	210	240
	B4	60	60	72	88	110	134	170	195
	B5	30	30	36	44	55	67	85	95
	B6	26	33.5 · 41.5	33.5 · 41.5	(33.5) · 45.5	59	67 · 83	85	116.5
	B7	5	5	6	(6) · 10	9	10 · 11	10	13.5
	B8	73	73	88	106	135	164	205	228
C	B9	M6 x P1.0	M6 x P1.0	M6 x P1.0	M8 x P1.25	M10 x P1.5	M12 x P1.75	M16 x P2.0	M16 x P2.0
	C1	106	106	127	156	197	223	267	309
	C2	57	57	68	84	109	121	142	162.5
	C3	49	49	59	72	88	102	125	146.5
	C4	1.25	1.25	2	2	2	2.25	2.25	2.5
	C5	33	33	44	55	75	72	82	92
D	C6	73	73	83	101	122	153	185	217
	D1	M4 x P0.7	M4 x P0.7	M5 x P0.8	M5 x P0.8	M8 x P1.25	M10 x P1.5	M10 x P1.5	M12 x P1.75
	D2	36	36	40	45	70	77	84	97
	D3	41.7	41.7	46.7	57.7	79.7	89.7	99.7	117.7
	D4	26	26	30	36	54	58	64	75
D5	15	15	18	22	34	38	42	54	
Weight ±3% (kg)	3.6	3.6	4.8	8.5	14.2	24	52		

ST-DP series

RATIO : 2.3.4.5 (單段 1-Stage)

單入力軸心 - 螺桿式

Single Input Shaft - Ball Screw

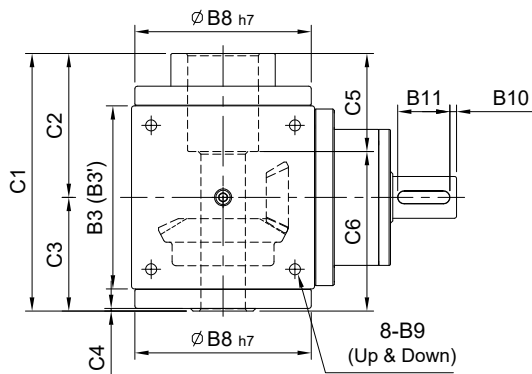

R 軸
Shaft Direction

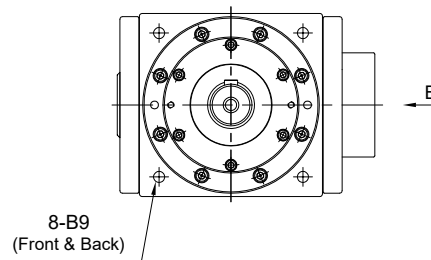
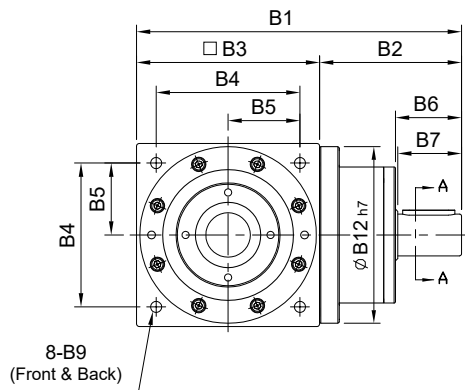
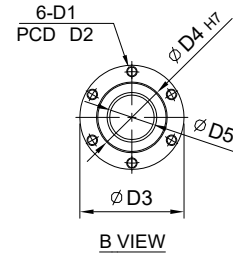
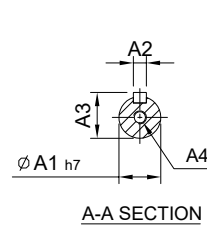

unit: mm

Model Code	75	90	110	140	170	210	240	
A	A1	16	18	22	32	40	55	
	A2	5	6	6	10	12	16	
	A3	18	20.5	24.5	35	43	59	
	A4	M5 x P0.8	M8 x P1.25	M8 x P1.25	M10 x P1.5	M12 x P1.75	M12 x P1.75	M16 x P2.0
B	B1	143	169	207	250	300	430	
	B2	68	79	97	110	130	190	
	B3(B3')	75(74)	90	110	140	170(168)	210	240
	B4	60	72	88	110	134	170	190
	B5	30	36	44	55	67	85	95
	B6	32	38	43	53.5	64	77	82
	B7	30	35	40	50	60	75	80
	B8	73	88	106	135	164	205	228
	B9	M6 x P1.0	M6 x P1.0	M8 x P1.25	M10 x P1.5	M12 x P1.75	M16 x P2.0	M16 x P2.0
C	B10	2.5	5	5	5	5	5	
	B11	25	25	30	40	50	65	70
	B12	73	88	106	135	164	205	228
	C1	106	127	156	197	223	267	309
	C2	57	68	84	109	121	142	162.5
	C3	49	59	72	88	102	125	146.5
D	C4	1.25	2	2	2	2.25	2.25	2.5
	C5	33	44	55	75	72	82	92
	C6	73	83	101	122	153	185	217
	D1	M4 x P0.7	M5 x P0.8	M5 x P0.8	M8 x P1.25	M10 x P1.5	M10 x P1.5	M12 x P1.75
	D2	36	40	45	70	77	84	97
D	D3	41.7	46.7	57.7	79.7	89.7	99.7	117.7
	D4	26	30	36	54	58	64	75
	D5	15	18	22	34	38	42	54
Weight ±3% (kg)		2.8	4.9	8.59	15.5	25	53	

ST-YP series

RATIO : 2.3.4.5 (單段 1-Stage)

雙入力軸心 - 螺桿式

Double Input Shaft - Ball Screw

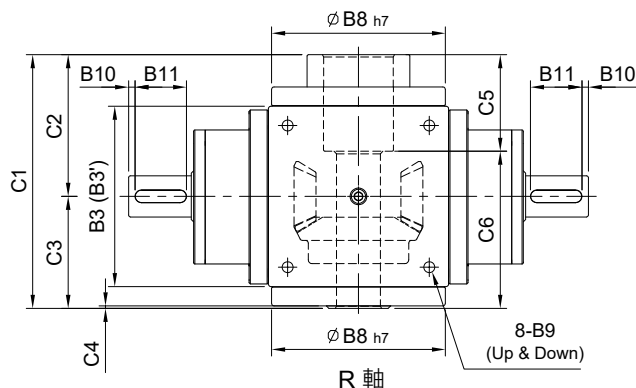

R 軸
Shaft Direction
B1

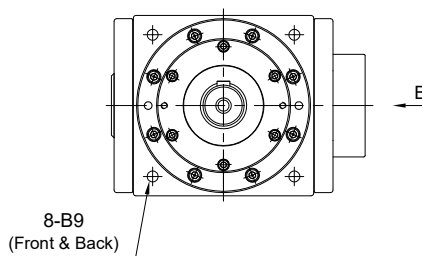
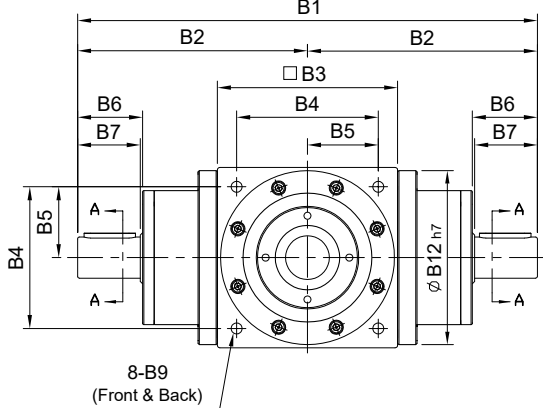
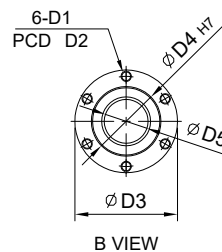
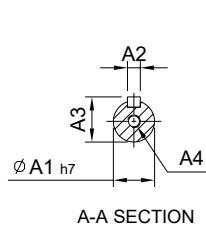

unit: mm

Model Code	75	90	110	140	170	210	240	
A	A1	16	18	22	32	40	55	
	A2	5	6	6	10	12	16	
	A3	18	20.5	24.5	35	43	59	
	A4	M5 x P0.8	M8 x P1.25	M8 x P1.25	M10 x P1.5	M12 x P1.75	M12 x P1.75	M16 x P2.0
B	B1	210	247	304	360	430	620	
	B2	105	123.5	152	180	215	310	
	B3(B3')	75(74)	90	110	140	170(168)	210	240
	B4	60	72	88	110	134	170	190
	B5	30	36	44	55	67	85	95
	B6	32	38	43	53.5	64	77	82
	B7	30	35	40	50	60	75	80
	B8	73	88	106	135	164	205	228
	B9	M6 x P1.0	M6 x P1.0	M8 x P1.25	M10 x P1.5	M12 x P1.75	M16 x P2.0	M16 x P2.0
	B10	2.5	5	5	5	5	5	5
	B11	25	25	30	40	50	65	70
	B12	73	88	106	135	164	205	228
C	C1	106	127	156	197	223	267	309
	C2	57	68	84	109	121	142	162.5
	C3	49	59	72	88	102	125	146.5
	C4	1.25	2	2	2	2.25	2.25	2.5
	C5	33	44	55	75	72	82	92
	C6	73	83	101	122	153	185	217
D	D1	M4 x P0.7	M5 x P0.8	M5 x P0.8	M8 x P1.25	M10 x P1.5	M10 x P1.5	M12 x P1.75
	D2	36	40	45	70	77	84	97
	D3	41.7	46.7	57.7	79.7	89.7	99.7	117.7
	D4	26	30	36	54	58	64	75
	D5	15	18	22	34	38	42	54
Weight ±3% (kg)	3.6	6.2	11.5	18	28	57		

Reference Information of Ball Screw

滾珠螺桿參考資料

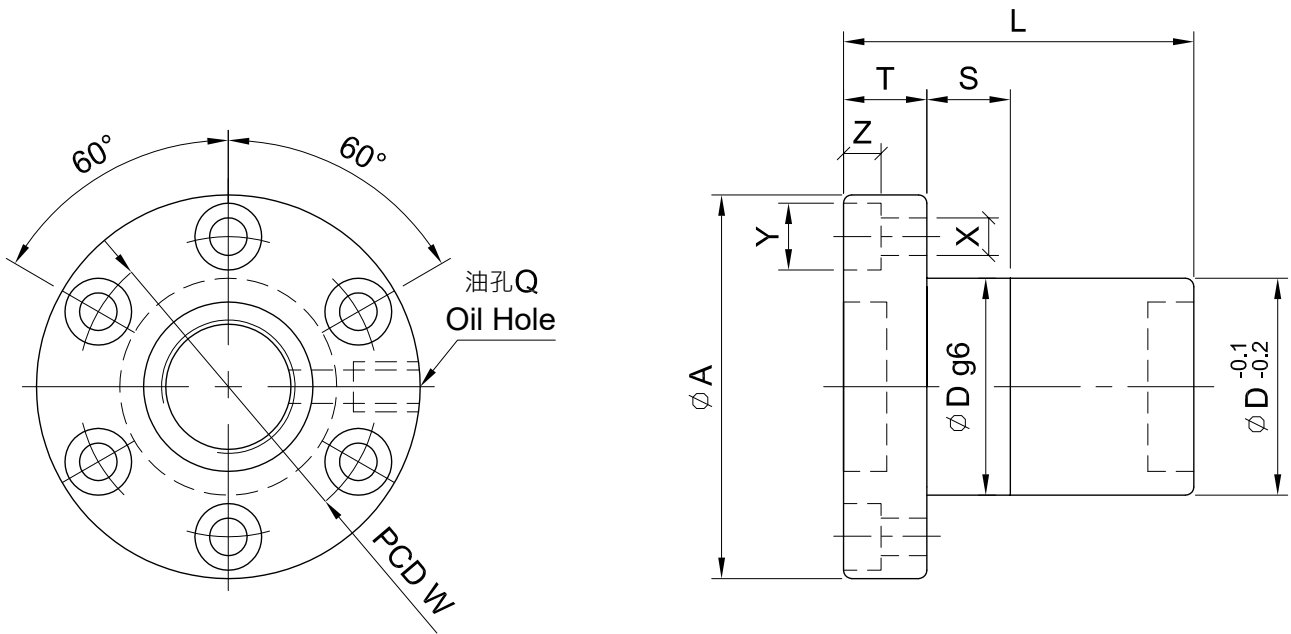
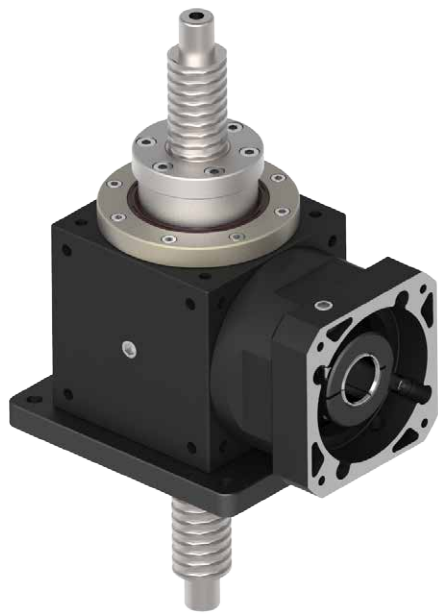

配合 減速機 型號 Model of Reducer	螺桿尺寸 Screw Size		基本額定負荷 Basic Rate Load (kgf)		螺帽 Nut		法蘭 Flange			配合 FIT	螺絲孔 Screw Bolt			油孔 Oil Hole	螺桿 長度 Length
	外徑 O.D.	導程 Lead	動負荷 Dynamic	靜負荷 Static	Dg6	L	A	T	W	S	X	Y	Z	Q	
75	14	5	720	1010	26	42	46	10	36	10	4.5	8	4.5	M6 x P1.0	≤ 500
90	16	6	980	1650	30	55	54	12	40	12	5.5	9.5	5.5	M6 x P1.0	≤ 800
110	20	10	860	1710	36	66	57	12	45	12	5.5	9.5	5.5	M6 x P1.0	≤ 1000
140	32	10	3340	7080	54	90	88	16	70	15	9	14	8.5	M8 x P1	≤ 1200
170	36	10	3600	8280	58	89	98	18	77	20	11	17.5	11	M8 x P1	≤ 1500
210	40	10	4670	11830	64	99	106	18	84	20	11	17.5	11	M8 x P1	≤ 1500
240	50	12	5770	14870	75	111	121	22	97	20	14	20	13	1/8"PT	≤ 1500

Fixing Plate

固定座

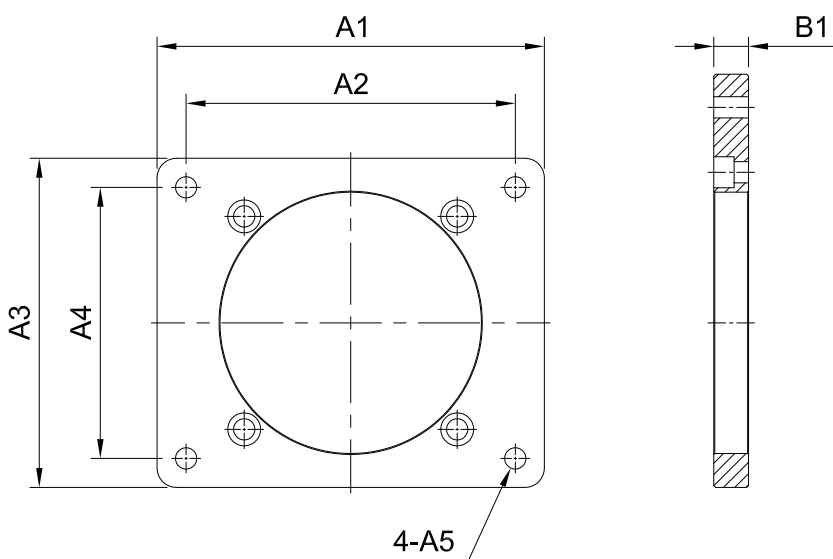
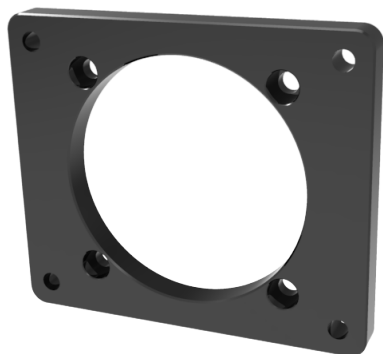

Indication of Fixing Plate

固定座料號表示

FP	90	F
固定座機型 Type	型號 Model	安裝方式 Direction
FP	65、75、90、110、 140、170、210	A、B、C、D、E、F

		unit:mm						
Model Code		65	75	90	110	140	170	210
A	A1	100	110	130	160	200	230	280
	A2	85	95	110	135	170	200	240
	A3	85	90	110	135	170	200	250
	A4	70	75	90	110	140	170	210
	A5	7	7	7	9	11	13	17
B	B1	10	12	13	16	18	18	25

Selection Direction of Fixing Plate

固定座安裝方式選擇

ST

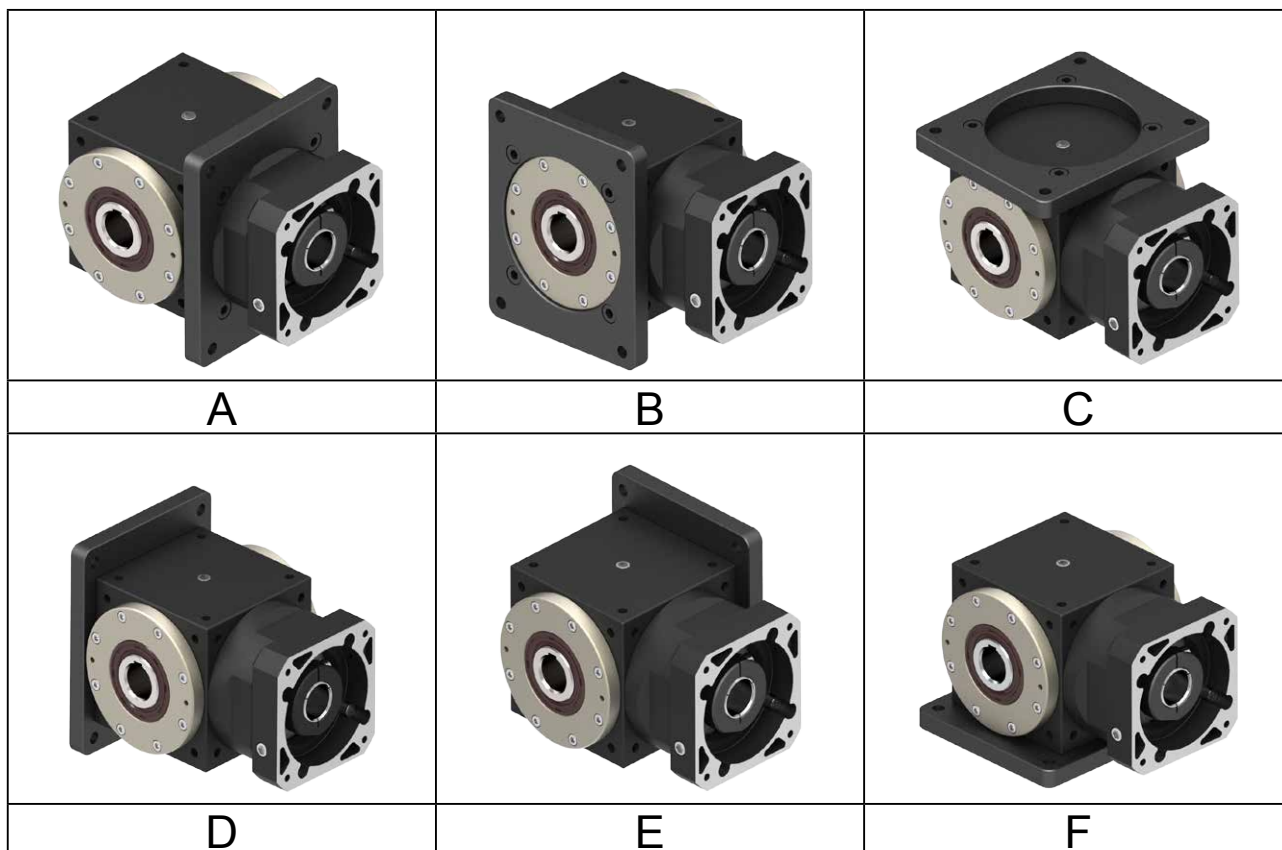

Installation Example of Fixing Plate

固定座安裝方式範例

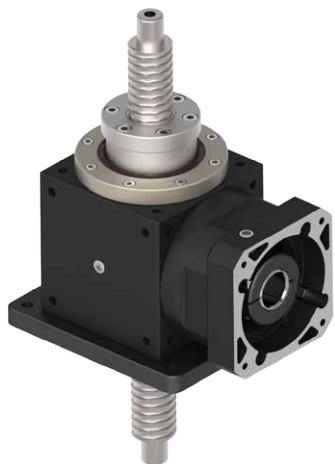

ST140-FPT-5 +
FP140-F

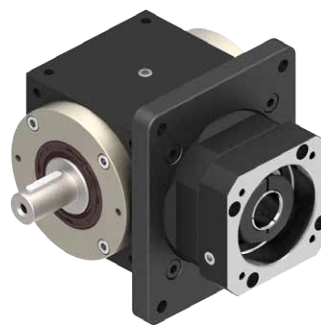

ST110-FSB-5 +
FP110-A

High Precision Spiral Bevel Gear Reducer and Motor Mounting Instructions 高精密螺旋傘齒輪減速機與馬達安裝指南

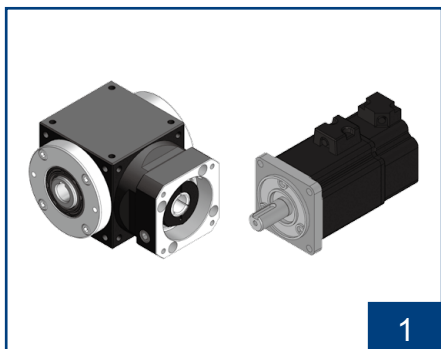

1

核對馬達型號與減速機規格是否正確。並將配合面擦拭乾淨。

Confirm the motor, and gearbox size. Clean up the mounting surface.

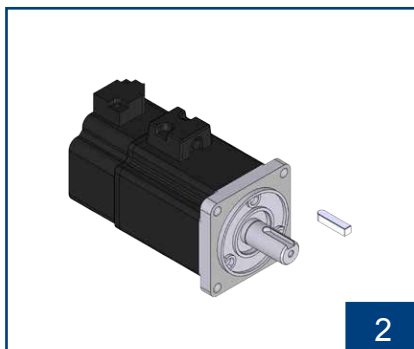

2

確認減速機與馬達是否有鍵配合。

Confirm whether the reducer and motor are keyed together.

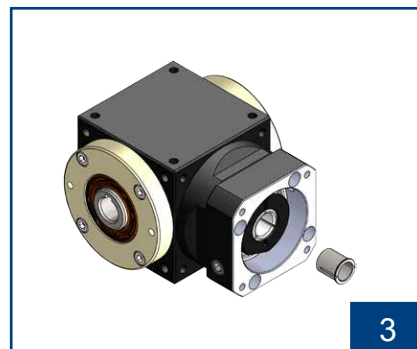

3

檢查馬達出力軸尺寸，如需軸套，請先裝進減速機入力孔內。

Check motor shaft size and insert bushing into input bore of the gear box if necessary.

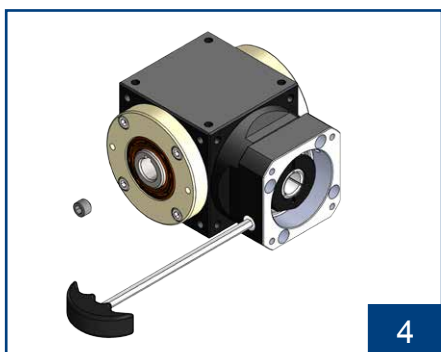

4

取出塞頭，使用六角扳手將迫緊環螺絲鬆開。並將扳手與螺絲對準孔位。

Remove the plug on the adapter plate. Rotate the set collar till the bolt is line up.



5

將馬達垂直裝入減速機。

Put the motor into the gearbox vertically.



6

依序 1~4 使用扭力扳手鎖上內六角螺絲。

Tighten the mounting bolt in 1~4 order with torque wrench.

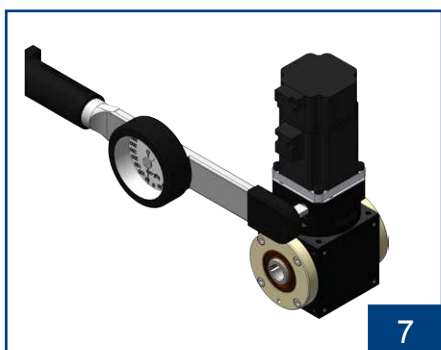

7

使用扭力扳手將迫緊環螺絲鎖緊。

Tighten the set collar bolt with torque wrench.



8

裝回塞頭並鎖緊。

Tighten back the screw plug.

1. 務必先鎖緊馬達固定面，才能鎖緊馬達軸心迫緊環。
Please be sure to tighten motor flange on gear box flange first and then to tighten the set collar on motor shaft.
2. 請依步驟順序組裝，尤其步驟 6、7 不可顛倒。
Please assembly in order according to above steps, especially for step 6 and step 7.
3. 安裝完畢後，請將塞頭回塞，避免細小物品掉入減速機中。
Please noted that tighten back the screw plug to protect the gear box.