

Bushing

軸套

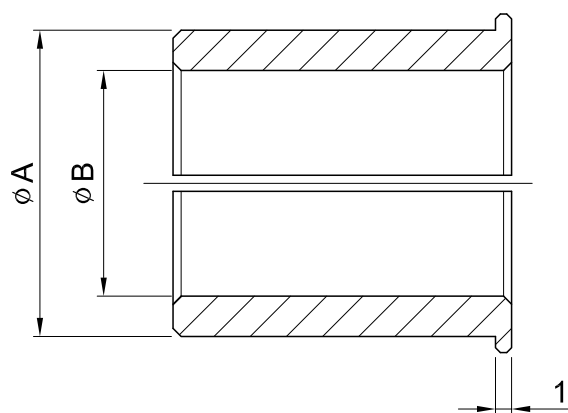

軸套內徑為所使用伺服馬達的輸出軸軸徑。
 下表中沒有的情況下需要插入軸套，在您所使用的輸出軸軸徑的近似值中選擇大值。
 For motor shaft diameters not listed, gearboxes will be supplied with a bush to suit.
 The bore sizes may be supplied as a larger bore with a bush.

連接軸 孔徑 Shaft Bore øA 軸套 孔徑 Bushing Bore øB	8	11	14	19	22	24	28	32	35
6	●	●							
6.35	●								
8		●							
9		●							
10			●						
11			●						
12			●						
12.7			●						
14				●					
15.85				●					
16				●		●	●		
19					●	●	●		
22						●	●	●	
24							●		●
28								●	●
32									●

Collet Locking Mechanism

筒夾式連結機構

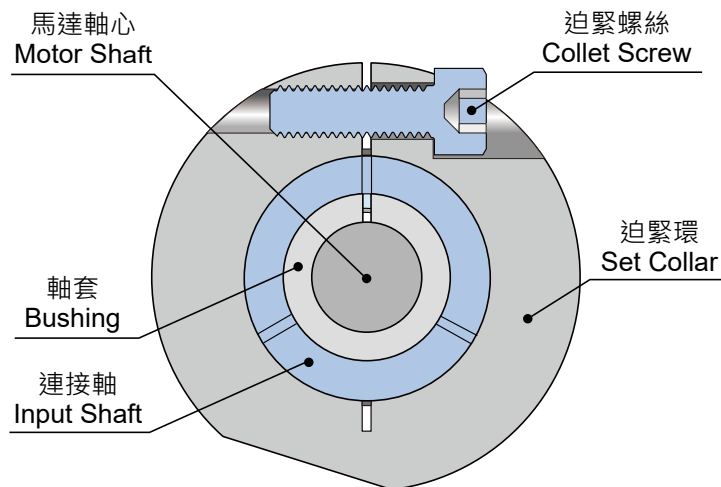

迫緊環螺絲及迫緊環扭矩表 Collet Screw & Collar Torque Table

Model					迫緊環螺絲規格 Spec. of Collet Screw	螺絲強度等級 Screw Grade	螺絲鎖緊扭矩 Tighten Torque (Nm)	迫緊扭矩 Clench Torque (Nm)
ST	HY	WE ANE	PW	GT				
-	55	30 40	30 40	60 85	M4 x P0.7	12.9	4.83	87
65 75	75	50	50 60 70	110 135 170(雙段 2-Stage) 200(雙段 2-Stage)	M5 x P0.8	12.9	10	164
90 110	90 115	60 70	-	170(單段 1-Stage) 200(單段 1-Stage)	M6 x P1.0	12.9	16.3	233
140	130	-	-	-	M8 x P1.25	12.9	41	423
170 210 240	140 160 190 230	-	-	-	M10 x P1.5	12.9	81	678
280	270	-	-	-	M10 x P1.5 M12 x P1.75	12.9	81 110	678 813

※ 馬達扭矩超過迫緊環扭矩時，可能導致打滑。It will cause slip when motor torque exceed clenched torque.

Clamping Sets

免鍵式軸套組

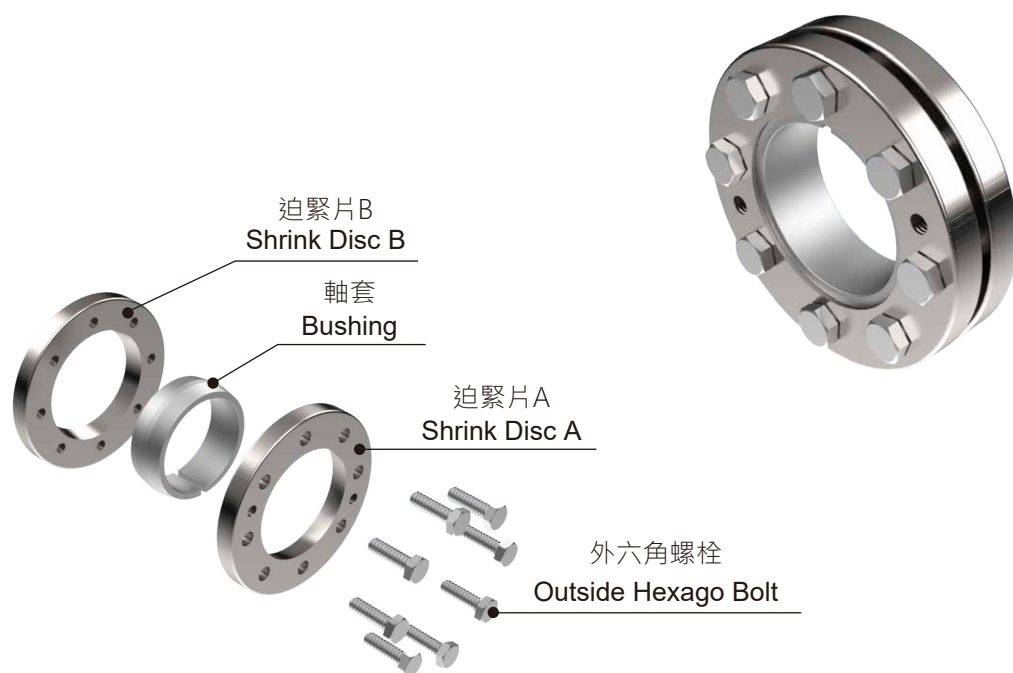

免鍵式軸套組 Clamping sets

Model			出力軸孔徑 Output Bore (mm)	螺絲規格 Spec. of Screw	螺絲鎖緊扭矩 Tighten Torque (Nm)	迫緊扭矩 Clench Torque (Nm)	螺絲數量 Quantity of Screw
ST	HY	WE · PW					
65 75	-	30	Ø14	M6 x P1.0	10	100	6
90	-	-	Ø18	M6 x P1.0	10	160	6
-	55	40	Ø20	M6 x P1.0	10	160	6
110	-	-	Ø22	M6 x P1.0	10	300	8
-	75	50 60	Ø25	M6 x P1.0	10	300	8
-	90	70	Ø30	M6 x P1.0	10	300	8
140	-	-	Ø32	M6 x P1.0	10	750	8
170	-	-	Ø40	M6 x P1.0	10	1000	8
-	115	-	Ø40	M6 x P1.0	10	750	8
-	130	-	Ø48	M8 x P1.25	34	900	8
210	-	-	Ø50	M8 x P1.25	34	2600	8
240	-	-	Ø55	M8 x P1.25	34	3376	12
-	140	-	Ø55	M8 x P1.25	34	1440	12
-	160	-	Ø60	M8 x P1.25	34	2200	12
280	-	-	Ø60	M8 x P1.25	34	4220	12
-	190	-	Ø70	M8 x P1.25	34	2880	12
-	230	-	Ø80	M10 x P1.5	40	4180	12
-	270	-	Ø90	M10 x P1.5	40	5440	12

Clamping Sets

免鍵式軸套組

免鍵式軸套組安裝指南

1. 檢查尺寸·減速機出力軸孔徑公差為 G6·與之配合的軸徑公差需為 h7。
2. 請清潔軸心與減速機出力軸孔徑及免鍵式軸套組安裝面的髒污和油漬。
3. 將免鍵式軸套組裝於減速機出力軸上·免鍵式軸套組需與出力軸端面齊平。
4. 放入至指定的位置後·依(圖一)順序手轉免鍵式軸套組螺絲·至迫緊片中間間隙平均對稱。
5. 使用扭力扳手依圖一順序將螺絲鎖至約 30% 的螺絲鎖緊扭矩。
6. 再依圖一順序將螺絲鎖至約 65% 的鎖緊扭矩。
7. 最後依圖一順序將螺絲鎖至約 100% 的鎖緊扭矩。
8. 以順時針方向檢查各螺絲是否達標準的鎖緊扭矩。

Clamping Sets Mounting Instructions

1. The tolerance of gear box's output bore is G6, the recommended tolerance of Shaft is h7.
2. Wipe off the output bore surface and Clamping Sets.
3. Put the Clamping Sets on the output shaft of the gearbox, make sure the it is flush with output shaft.
4. Please insert the screw by hand after assembling the shrink Disc B and shrink Disc A.
5. Tighten the locking screws using a torque wrench follow Figure 1 step, beginning lightly (approx. 30% of the predetermined tightening torque).
6. Tighten the screws further to an increased torque (approximately 65% of specified torque).
7. Tighten the screws up to the specified torque.
8. Finally checking the locking screws in circumferential order.

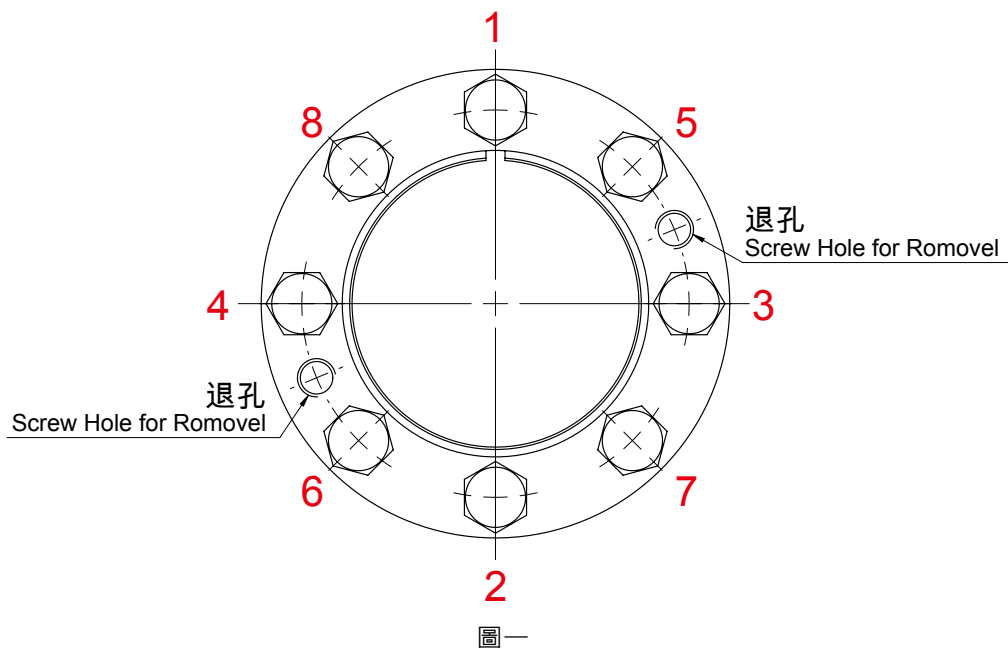

免鍵軸套拆卸

1. 依圖一順序鬆脫螺絲
請勿一次性將螺絲完全拆卸·避免免鍵式軸套組拆卸時導致迫緊片彈出。
2. 將螺絲鎖進圖一的退孔螺絲孔·以對稱力量方式鎖固螺絲·至迫緊片鬆脫·即可取出

Clamping Sets Disassembly

1. Please follow the Figure 1 step by step to loose the screw, the shrink Disc may pop out if loose the screw at one time.
2. Insert a screw in a hole for removal and tighten evenly.

Selection Table of Motor for Reference

馬達選用參考表

單段 1-Stage

Model	ST	-	-	65	-	75	-	90	-	110	140	170	210	240	280		
	FT	42	50、60	-	70	-	-	-	-	-	-	-	-	-	-		
	HY		55	-	75	-	90	-	-	115	130	140	160	190、230	-	270	
	WE	-	30	-	40	50	-	-	60、70	-	-	-	-	-	-	-	
	GT	60	-	-	85、110	135	-	-	170、200	-	-	-	-	-	-	-	
Power	Input Bore	8	8	9	14	14	14	16	19	19	24	32	35	42	48	55	
		8	9	11	14	19	19	22	24	24	28	32	35	38	48	55	60
100 W	●	●	●														
200 W			●														
400 W			●	●	●	●	●										
750 W					●	●	●	●	●								
1 kW						●	●	●	●	●	●						
1.5 kW							●	●	●	●	●						
2.2 kW											●						
3.75 kW											●	●	●				
5.5 kW												●	●				
7.5 kW													●				
11 kW														●			
15 kW														●	●		
22 kW														●	●	●	
30kW														●	●	●	●

雙段 2-Stage

Model	ST	-	-	65、75	75	-	110	140	-	-	170	-	210	240	280		
	FT	-	50、60	70	-	-	-	-	-	-	-	-	-	-	-		
	HY	-	-	55	75	-	90	115	-	-	130	140	160	190	230、270		
	PW	-	30	40	-	50	-	-	60、70	-	-	-	-	-	-		
	GT	60	-	-	-	85、110	135	-	-	-	170	-	-	-	-		
Power	Input Bore	8	8	8	11	14	14	16	19	19	22	28	28	35	42	48	55
		8	9	9	14	14	16	19	22	24	19	24	28	32	35	38	42
100 W	●	●	●	●													
200 W			●	●													
400 W			●	●	●	●	●										
750 W				●		●	●	●	●								
1 kW							●			●	●						
1.5 kW								●		●	●						
2.2 kW											●	●	●				
3.75 kW											●	●	●	●			
5.5 kW												●	●	●			●
7.5 kW												●	●				●
11 kW														●	●		●
15 kW														●	●		●
22 kW														●	●		●
30 kW														●	●		●