

MODEL : FD60

雙段 2-Stage

RATIO : 15, 20, 25, 30, 35, 40, 50, 70, 100

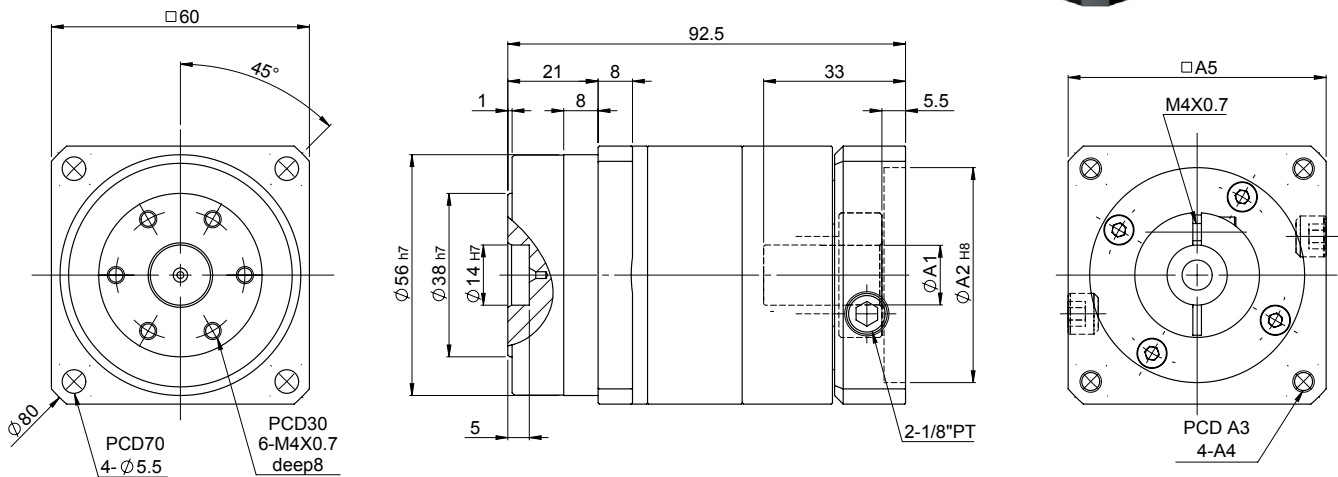
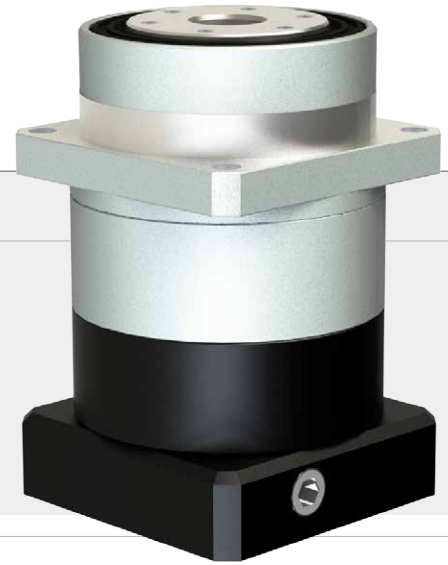

入力法蘭尺寸表 Dimension of Input Flange

unit: mm

No.	ØA1	ØA2	A3	A4	A5
1	8・9・10・12.7・14	30	45	M3	46
2		30	46	M4	46
3		30	48.5	M3	55
4		40	63	M5	55
5		50	70	M5	60

規格 Parameter	代號	單位 Unit	15	20	25	30	35	40	50	70	100
額定輸出扭矩 Rated Output Torque (Nominal output torque)	T_{2N}	Nm	15	20	25	30	35	40	50	70	100
轉動慣量 Mass Moments of Inertia		kg.cm ²	50	68	22	50	63	68	72	63	45
最大加速扭矩 Max. Acceleration Torque	T_{2B}	Nm	1.8 倍額定輸出扭矩 1.8 Times of Rated Output Torque								
最大輸出扭矩 Max. Output Torque 急停扭矩 Emergency Stop Torque	T_{2NOT}	Nm	3 倍額定輸出力矩 3 Times of Rated Output Torque								
額定輸入轉速 Rated Input Speed	n_{IN}	rpm	3,000								
最大輸入轉速 Max. Input Speed	n_{IB}	rpm	5,000								
扭轉剛性 Torsional Rigidity		Nm/arcmin	4								
容許徑向力 Max. Radial Force	F_{2rB}	N	460								
容許軸向力 Max. Axial Force	F_{2aB}	N	230								
使用壽命 Service Life	L_H	hr	S5 周期運轉 : >30,000 (S1 連續運轉 : >15,000 hrs) S5 Cycle Operation: >30,000 (S1 Continuous Operation: >15,000 hrs)								
效率 Efficiency	η	%	≥ 97%								
使用溫度 Operating Temperature		°C	- 25° C ~ + 90° C								
潤滑 Lubrication			全合成潤滑油脂 Synthetic Grease								
防護等級 Protection Class			IP 65								
安裝方向 Mounting Position			任意 Any								
噪音值 Noise Level		dB	≤ 58 dB								
重量 Weight ±2%		Kg	1.24								